



## Overview

The USBExt3c is a managed two-port USB-C extender and programmable hub designed for enterprise, industrial, and AV environments. It supports:

- Local USB links up to 5 Gbps (USB 3.2 Gen 1)
- USB 3.2 Gen 1 (5 Gbps) and USB 2.0 extension up to 100 m over Cat 6A cable (HDBaseT-USB3)
- Bidirectional PoE++ power extension
- Automatic AnyPort™ host switching from either end of the extension

When powered over the extension, the USBExt3c provides up to 60 W of total USB PD output across all USB ports. Up to 90 W of shared power is available when powered locally.

Full software control of the USBExt3c is available using the interactive HubTool App or BrainStem® API via the upstream-host connection, Ethernet, or dedicated USB-C Control Port.

## Typical applications

- USB-C range extension in enterprise and industrial environments
- Industrial and A/V camera extension
- BYOD Video Conferencing systems
- Device compatibility test labs
- Remote USB PD monitoring, control and power cycling

## Functions

### Data

- Local links up to 5 Gbps (USB 3.2 Gen 1)
- Extension of USB 3.2 Gen 1 (5 Gbps) and USB 2.0 up to 100 m over Cat 6A via HDBaseT-USB3
- Backward compatible with USB 2.0 / 1.x devices
- Per-port selective enable/disable of HS, SS, and V<sub>BUS</sub>
- Link speed detection per port
- RS-232 and GPIO signal extension over the link
- Low-latency frame synchronization via GPIO

### Power

- USB Power Delivery per port: source up to 60 W or sink up to 100 W
- Programmable per-port current limits
- USB legacy-charging support: SDP (Standard Downstream Port) and CDP (Charging Downstream Port)
- Voltage and current measurement on each port's V<sub>BUS</sub>
- Power through PoE++ or via any USB-C port

### Control and Management

- Control via HubTool or BrainStem API
- Control Interfaces: upstream-facing host port, Ethernet, RS-232, or dedicated Control Port
- When used as an extender pair, the second USBExt3c can be controlled through the extension
- AnyPort™ allows host port assignment for ports on either end of the extension
- Configurable enumeration delay for attached downstream devices
- USB PD profile monitoring and control

### Industrial hardware

- DIN-rail mountable for industrial installations
- Screw retention on all USB-C ports
- ±15 kV ESD protection (IEC 61000-4-2 Level 4)
- All pins protected against overvoltage and reverse polarity

**System Block Diagram**

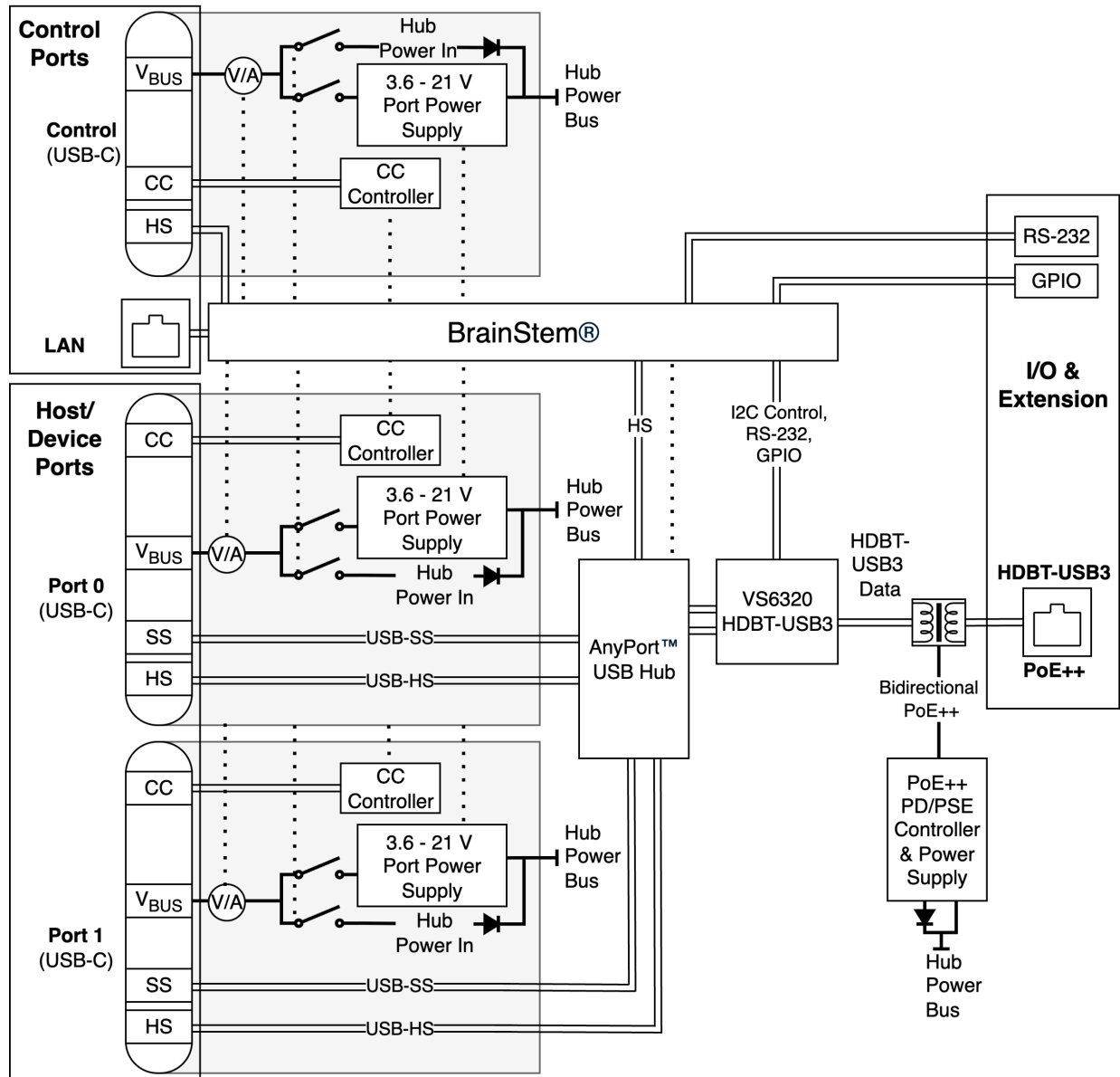

Figure 1: USBExt3c Block Diagram



### Applications

#### Camera Extension

##### AV back-of-room camera extension

A USBExt3c pair makes it possible to position 4K PTZ or auto-tracking USB cameras at the back of a room for instructor / presenter view without requiring local power. If the camera has integrated HDBaseT-USB3 and PoE support, a single USBExt3c can provide data and power to the camera over one Cat 6A cable.

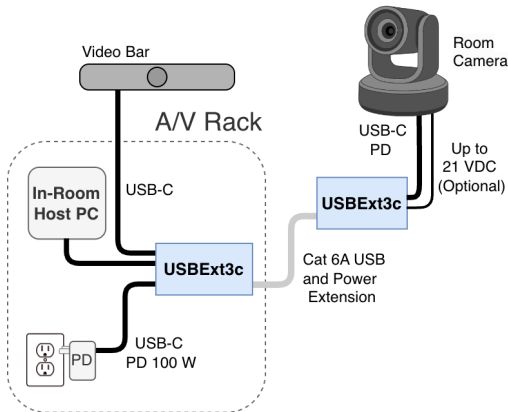

Figure 2: Back-of-room camera extension

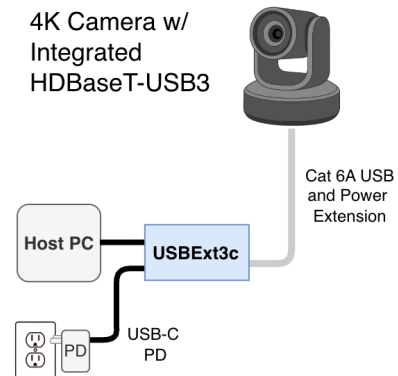

Figure 3: Host interface for cameras with integrated HDBaseT-USB3

#### BYOD / BYOM Systems

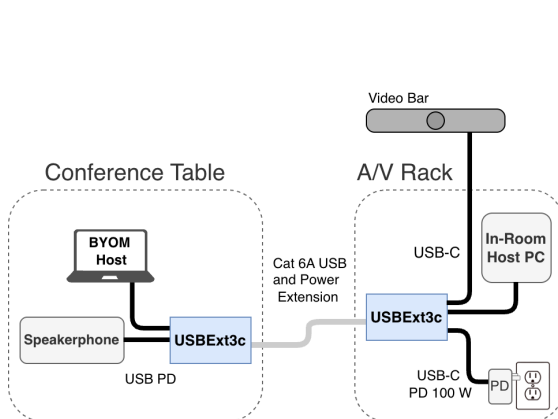

Figure 4: BYOD/BYOM conference table example

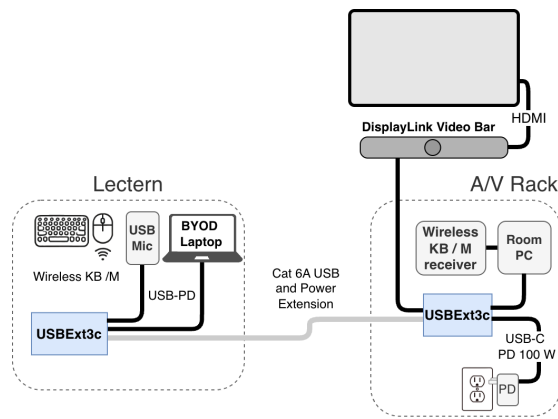

Figure 5: BYOM lectern example

AnyPort™ switching allows automatic handoff between a room PC and a laptop for Bring Your Own Meeting (BYOM) scenarios where the laptop temporarily drives the room peripherals. Video can be shared from the BYOM laptop via DisplayLink (with supported A/V hardware and DisplayLink drivers). Up to 60 W of power is available to devices on the conference table or lectern without requiring an outlet for local power.

### Industrial camera extension

For machine vision, the USBExt3c extends and powers USB3 Vision cameras while carrying RS-232 and GPIO / frame sync signals. It can also provide USB PD or programmable DC power output (up to 21 V) to drive lights, sensors, or actuators.

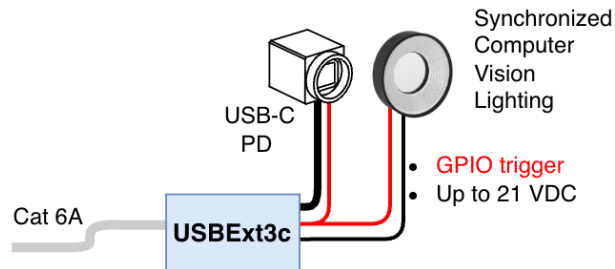

Figure 6: Extension for USB3 Vision cameras with triggered frame sync and auxiliary DC power

### Device testing and automation

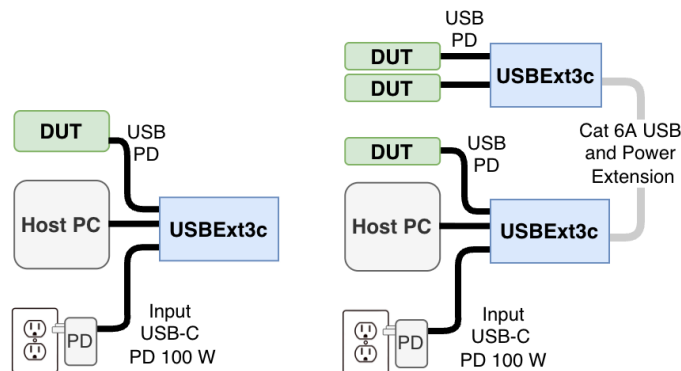

Figure 7: Standalone and extender configurations for test applications

**Standalone mode:** single host / device link

- Use one USBExt3c to connect a host directly to a device
- Port-level features enable:
  - USB Port testing (including cable flip)
  - USB PD verification and logging
  - Remote port cycling and monitoring via Ethernet without requiring physical access

**Extender mode:** solve power, isolation, distance limitations

- Flexible location for host computers / test runners in crowded device labs
- Locate hosts outside of cleanrooms, work cells, or restricted zones
- Provide remote power via PoE++ where AC outlets are unavailable
- Galvanic isolation of power and data
  - Prevent ground loops
  - Protect devices from surges, noise, and faults

### Cable Flip testing

USB-C receptacles must support either cable orientation. With an Acroname **Universal Orientation Cable (UOC)**, the USBExt3c can programmatically flip cable orientation, forcing the Device Under Test to reconfigure signal paths.

### **UOC Selection**

Device USB-C ports either **short** sides A and B USB 2.0 (HS) data lines or use a **mux** to keep the two sides electrically independent. Choose the UOC that matches your DUT port:

**C70:** routes both CC lines and **two HS pairs**, for devices with **muxed USB 2.0 sides**

**C67:** routes both CC lines and **one HS pair**, for devices with **shorted USB 2.0 sides**

### **Usage**

When using C67 on a device with shorted USB 2.0 sides, set Data > HS routing to "A" or "B" to connect to the single USB 2.0 pair in the cable.

To initiate a virtual cable flip:

- Enable CC1 or CC2
- If using C70, connect D+ / D- to the corresponding USB 2.0 lines.

## Indicators and Connections

### Front Panel

The front of the USBExt3c contains three USB-C receptacles (Control, Port 0, and Port 1) and one Ethernet port. The Control and Ethernet ports are dedicated for control communication between a computer and the USBExt3c. Port 0 and Port 1 connectors are full-featured hub ports. When configured as an upstream port, each can also be used for control.

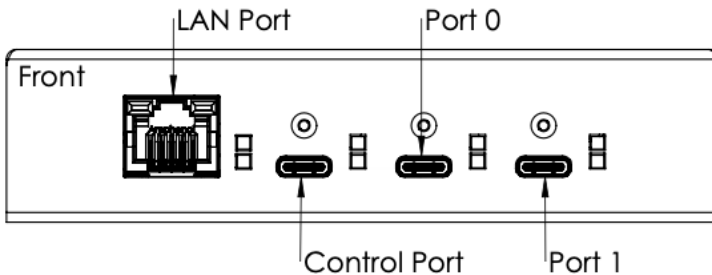

### Rear Panel

The back of the USBExt3c contains an HDBaseT-USB3 port and a 4-pin expansion connector for RS-232, frame sync, and GPIO. Chassis ground is accessed through a grounding screw.

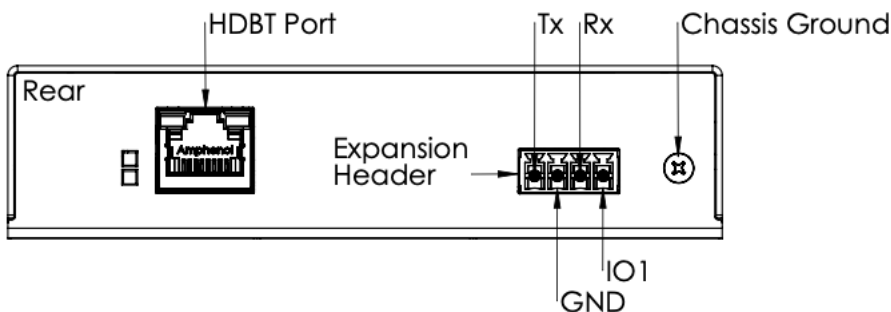

#### Expansion Connector

The USBExt3c expansion connector is a 4-pin, 1-row, shrouded male header block with 3.81mm pitch (Mating Phoenix Contact 1803594). This interface provides additional mechanisms for expandability and testing scenarios.

Connection Name	Pin Number	Description
TX	1	RS232 Serial Transmit (data from USBExt3c)
GND	2	Ground
RX	3	RS232 Serial Receive (data to USBExt3c)
IO1	4	General Purpose IO, Frame Sync

Table 1: Expansion Connector Pinout

#### LEDs

Both the front and back panels of the USBExt3c have status LEDs to communicate device status and behavior. The names and meanings of these LEDs are explained in the image and table below.

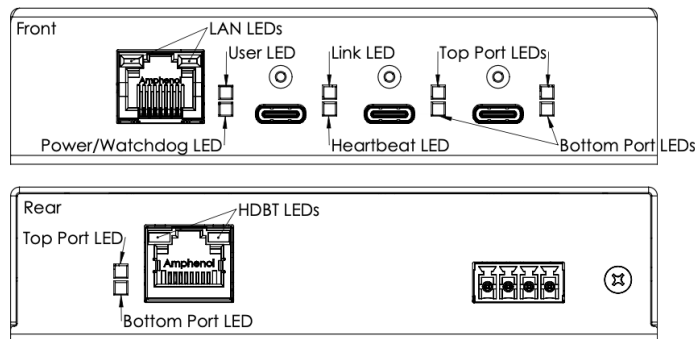

Type	Icon	LED Name	Color	Description
System	Person	User LED	Blue	User-controllable LED
	Power Icon	Power / Watchdog	Red / Magenta	Alternating Red and Magenta when powered
Control	Chain Links	BrainStem@ Link	Yellow	Link Present
	Heart	BrainStem@ Heartbeat	Green	Blink when Heartbeat received
HDBaseT-USB3	None	HDBaseT-USB3 LEDs	Green Amber	Solid Green: USB 3 link exists Solid Amber: HDBaseT-USB3 link exists Both flash during VS6320 firmware update
Port status (USB-C and HDBaseT-USB3)	None	USB Enumeration Speed (Top LED)	Yellow	USB 2.0 Hi-Speed up to 480 Mbps
			Green	SuperSpeed 5 Gbps
		UFP/DFP (Bottom LED)	Blue	SuperSpeed+ 10 Gbps
			Magenta	Upstream (UFP) port
Ethernet	None	Ethernet Activity	Green	Green LED is solid when a link exists
			Amber	Amber LED blinks during activity

Table 2: LED indicators

## Unit Reset

The bottom of the case has a recessed reset button (see [Figure 12](#)). Various press sequences can be performed on the button:

Press Sequence	Outcome
Single press	Unit resets, equivalent to a power-cycle
Double Press within 5-seconds	Unit performs a factory reset, restoring all settings to factory defaults
Long Hold for 5-seconds	Unit enters firmware recovery mode

Table 3: Unit reset options

## Feature Descriptions

Each USBExt3c is addressable and controllable from a host system via USB-C Control Port, Ethernet (TCP/IP), RS-232, or via a second USBExt3c over the HDBaseT-USB3 Link. Once connected, a BrainStem® link is established to the onboard controller, enabling software control through the BrainStem® API. This API provides full access to all module functionality from a host system.

### USB Ports

The two full-featured ports (0 and 1) can be configured as upstream-facing host ports or downstream-facing device ports. The ports implement separate, independently switched USB HS and SS data, CC,  $V_{CONN}$  and current-limited  $V_{BUS}$  lines, supporting advanced USB testing applications.

The dedicated USB-C control port is a high-speed USB 2.0 connection for BrainStem® interface and device power only. No other USB traffic can flow on this connection. See the *Port API* for more detail.

### Automatic Host Port Switching Behavior

By default, any time a host-capable device is connected to any port on either end of the extension, it will become the host. This enables simple host switching for BYOD/M conference rooms: a laptop can temporarily take control of room AV equipment to host a meeting. When the laptop disconnects, the dedicated room PC becomes the host and regains control of the peripherals.

### Programmatic Host Switching

For static installations or when a controller is managing host selection, port roles can also be assigned manually via the Brainstem® API or Hubtool. For each USBExt3, the upstream-facing port role can be assigned to either port or to the HDBaseT-USB3 extension link.

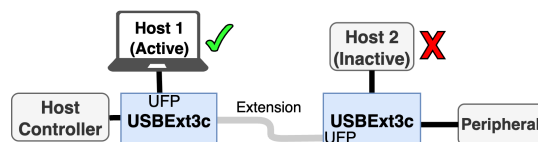

Figure 8: Programmatic host switching with host controller

### RS-232 Extension

By default, RS-232 connections are extended in oversampled mode where data is sampled, transmitted, and reconstructed at the other end extension. Baud rates up to 150 kBaud are supported (1/10 of the 1.5 MHz sample rate).

The RS-232 port can also be configured to control the USBExt3c.

#### GPIO Extension

The GPIO pin provides low latency (< 20  $\mu$ s) extension of a trigger signal. By default, the host side extender acts as the GPIO input and the device-side extender as the GPIO output. Low-latency trigger extension is useful for frame synchronization for industrial camera installations. This default configuration can be changed using the Brainstem® API

#### Flexible Power Routing

The USBExt3c accepts power through any USB-C port and will operate with as little as 5 V (900 mA) for data-only extension, receiving power through the host USB connection. For example, the host-side USBExt3c could be powered by the host, while the device-side extender receives 5 V 1500 mA from a power adapter connected to the Control port (Figure 9).

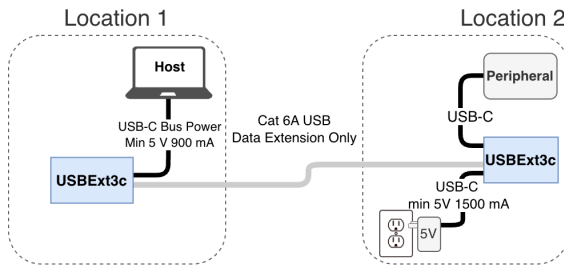

Figure 9: Minimal local power configuration

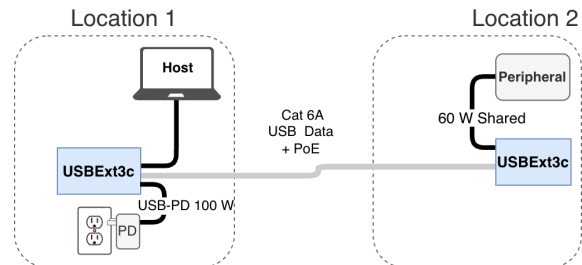

Figure 10: Power extension

To power a pair of USBExt3c from a single power source (with PoE power provided to the second USBExt3c), the input power supply must provide between 45 W and 100 W. When a single 100 W supply is connected to one USBExt3c, up to 60 W is available to devices on the second USBExt3c (Figure 10). For maximum device power, connect a 100 W USB PD supply to each USBExt3c to provide 90 W shared per extender (Figure 11).

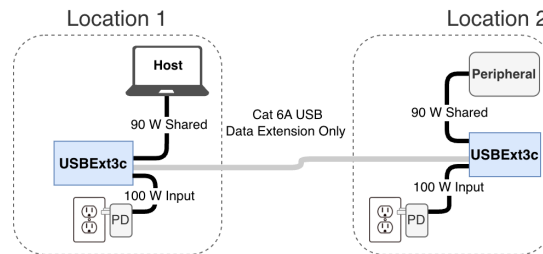

Figure 11: Maximum device power is available when both USBExt3c extenders are powered

#### Ethernet Control

The USBExt3c can be managed over Ethernet using the HubTool application, BrainStem® API, REST interface, or built-in web interface. Connections are made through the Ethernet jack using TCP/IP sockets and are supported on the local link segment only. For most setups, we recommend a direct Ethernet link between the host test machine and the USBExt3c.

When using a pair of USBExt3c connected by HDBaseT-USB3, only one Ethernet connection is required; the second device is available through Brainstem® networking over the extension link.

By default, the USBExt3c acts as a DHCP client and will receive an IP address from a DHCP server. If no server is detected, the USBExt3c falls back to a static IP address of **192.168.44.42**. In static mode, the host computer interface IP must be set to an address in the **192.168.44.x** range. The DHCP client is limited to hosts on the local link and does not operate across network bridges or gateways.

The USBExt3c responds to ICMP “ping” requests including broadcast pings. The Brainstem® API interface performs a discovery process prior to establishing communication by sending a UDP multicast request on port 9888. The USBExt3c responds with a message to UDP port 9889. The USBExt3c listens for socket connections on TCP port 8000. The Rest interface uses TCP on ports 9005 and 9006

Host firewall rules must allow:

- Outgoing UDP multicast on port 9888
- Incoming UDP responses on port 9889
- Outgoing TCP connections to port 8000
- Incoming / Outgoing TCP connections on ports 9005 and 9006

### **HDBaseT-USB3 Configuration**

The HDBaseT-USB3 port provides simultaneous extension of USB SuperSpeed, High-speed, RS232, and GPIO / frame sync data over Cat 6A cable, along with bidirectional PoE++ Power. The HDBaseT-USB3 link direction is automatically negotiated by default. The direction can also be manually configured for fixed installations.

Detailed HDBaseT-USB3 link parameters from either extender in the pair can be viewed in HubTool or accessed through the BrainStem® API, including:

- Index (local or remote)
- State (Device present, Link role and status)
- Serial Number
- VS6320 Firmware Version
- Cable Length (m)
- Mean Squared Error ( $\mu$ B)
- Retransmission rate (# messages between retransmission, 0 = no errors)
- Link Utilization ( $\mu$ %)
- Encoding state (e.g. PAM 8)

### **PoE++ Configuration**

The fully bidirectional Power-Over-Ethernet (PoE++) subsystem allows a pair of USBExt3c units to operate from a single power source, or to power other PoE-compliant devices (IEEE 802.3bt Class 7), with full software monitoring and control of the power link.

The PoE++ system will automatically manage power extension based on power sources and loads on either end of the extension. However, for testing, diagnostics, and advanced applications, manual control and monitoring is provided, including:

#### **Control:**

- Set Power Mode: PSE / PD / Auto (Default) / Off
- Set Sourcing Class Signature for pairs 1-2 and 3-4

#### **Monitoring:**

- Power State (PD / PSE / Off)
- Requested Class (Class requested from PD to PSE)

For pairs 1-2 or 3-4:

- Sourcing Class (PoE class PD is trying to source)
- Discovered Class (negotiated class)
- Detection Status (valid connection, short, open, Hi Z, Lo Z)
- Voltage ( $\mu$ V)
- Current ( $\mu$ A)
- Resistance ( $m\Omega$ )
- Capacitance ( $\mu$ F)
- Power (mW)
- Accumulated Power (mWh)

## Absolute Maximum Ratings<sup>1</sup>

Stresses beyond those listed under ABSOLUTE MAXIMUM RATINGS can cause permanent damage to the device. These are stress ratings only and functional operation of the device at these or any other conditions beyond those indicated under RECOMMENDED OPERATING CONDITIONS is not implied. Exposure to absolute-maximum rated conditions for extended periods affects device reliability and may permanently damage the device.

Parameter	Minimum	Maximum	Units
V <sub>BUS</sub> Power per USB-C Port		100	W
Voltage on any V <sub>BUS</sub>	0.0	24	V
Current on any V <sub>BUS</sub>	-5	5	A
Voltage on any USB SS+/SS-	-0.3	24	V
Voltage on any USB D+/D-	-0.3	5	V
Voltage on CC1 and CC2	-0.3	5.6	V
Expansion Header Rx/Tx	-25	25	V
Expansion Header IO1	-25	25	V
Altitude		2000	M
Overvoltage		Overvoltage Category I	

Table 4: Absolute Maximum Ratings

## Handling Ratings

Parameter	Conditions/Notes	Minimum	Typical	Maximum	Units
Storage Humidity Range	Non-Condensing	5	-	95	%RH
Storage Temperature, T <sub>STG</sub>		-10	-	85	°C
Mass		-	0.6	-	kg
Electrostatic Discharge, V <sub>ESD</sub> Meets IEC 61000-4-2, level 4	Air-discharge	-15	-	15	kV
	Contact-discharge	-8	-	8	kV

Table 5: Handling Ratings

## Recommended Operating Ratings

Specifications are valid at 25°C unless otherwise noted. Intended for indoor use only.

Parameter	Conditions/Notes	Minimum	Typical	Maximum	Units
Ambient Operating Temperature, T <sub>A</sub>		0	25	30	°C
Relative Humidity Range	Non-Condensing	5	-	80	%RH
USB V <sub>BUS</sub> on ports	Hub powered; Port power enabled	3.6	5.2	21.0	V

Table 6: Recommended Operating Rating

<sup>1</sup> If the equipment is used in a manner not specified by the manufacturer, the protection provided by the equipment may be impaired.

## Typical Performance

### System Characteristics

Specifications are valid at 25°C unless otherwise noted. Indoor use only. Sample rates are typically limited by the USB throughput of the host operating system.

Parameter	Conditions/Notes	Min	Typ.	Max	Units
Input Power, $W_{V_{BUS}}$ , no downstream devices attached	HDBaseT-USB3 Link Active	-	5	-	W
System Input current Type-C port, $I_{V_{BUS}}$	Dependent upon USB-C supply and Load	100	-	5000	mA
Measurement Sampling Rate			100		Hz

Table 7: Typical Performance Characteristics

### USB-C Port Characteristics

Specifications are valid at 25°C unless otherwise noted. Indoor use only.

Parameter	Conditions/Notes	Min	Typ.	Max	Units
$V_{BUS}$ Source Power		-	-	60	W
$V_{BUS}$ Sink Power		-	-	100	W
$V_{BUS}$ Output Voltage		3.6	5.2	21.0	V
$V_{BUS}$ Voltage Measurement Full Scale Range		0		32	V
$V_{BUS}$ Voltage Measurement Resolution		-	488	-	$\mu$ V
$V_{BUS}$ Voltage Measurement Accuracy		-0.5	-	0.5	%FSR
$V_{BUS}$ Voltage Setpoint Resolution		-	100	-	mV
$V_{BUS}$ Voltage Ripple	Peak to peak at target $V_{BUS}$ voltage	-	-	300	mV
$V_{BUS}$ Current Limit Nominal Values	0.5, 1.0, 1.5, 2.0, 3.0, 4.0, 5.0				A
$V_{BUS}$ Current Measurement Full Scale Range		-10	-	10	A
$V_{BUS}$ Current Measurement Resolution		-	300	-	$\mu$ A
$V_{BUS}$ Current Measurement Accuracy		-0.5	-	0.5	%FSR
USB SuperSpeed Data Rate	Host and device dependent	-	-	5	Gbps
USB Hi-Speed Data Rate	Host and device dependent	-	-	480	Mbps
$V_{BUS}$ Current Supply (SDP mode)	USB 2.0 data lines enabled, USB host present, device limited	-	500	-	mA
$V_{BUS}$ Current Supply (CDP mode)	USB 2.0 data lines enabled, USB host present, device limited	-	1500	-	mA
$V_{BUS}$ Current Supply (DCP mode)	USB 2.0 data lines enabled, no USB host present, device limited	-	5000	-	mA
$V_{conn}$ Output Voltage		4.0	5.2	5.5	V
$V_{conn}$ Output Voltage Ripple	Peak to Peak	-	-	100	mV
$V_{conn}$ Current Output		-	-	400	mA
$V_{conn}$ Line Capacitance		-	25	-	pF

Table 8: USB-C port characteristics

### External Header Characteristics

Specifications are valid at 25°C unless otherwise noted. Indoor use only.

Parameter	Conditions/Notes	Min	Typ.	Max	Units
IO1 Output Voltage High $V_{OH}$	Without external pull-up resistor	-	5.2	-	V
IO1 Output Voltage Low $V_{OL}$	Without external pull-up resistor	-	0.7	-	V
IO1 Input Voltage High $V_{IH}$	Valid input high	3.6	-	-	V
IO1 Input Voltage Low $V_{IL}$	Valid input low	-	-	3.0	V
IO1 End-to-end Latency over extension		-	-	20	$\mu$ s
IO1 Jitter		-	-	1	$\mu$ s
RS-232 Baud Rate		-	-	1	Mbps

Table 9: External Header characteristics

### HDBaseT-USB3 Port Characteristics (TBD)

Specifications are valid at 25°C and Cat6A 23AWG U/FTP cable unless otherwise noted. Indoor use only.

Parameter	Conditions/Notes	Min	Typ.	Max	Units
HDBaseT-USB3 Pins	Compatible with HDBaseT-USB3				
HDBaseT-USB3 Extension Distance	PoE disabled	-	25	100	m
	PoE enabled	-	25	70	m
PoE Power <sup>2</sup>	PSE output, Supports classes 1-7	-	-	75	W
	PD input, Supports classes 1-8	-	-	71.3	W
Galvanic Isolation	From pins 1-8 to GND	1500	-	-	V

Table 10: Operating specifications

### LAN Port Characteristics

Specifications are valid at 25°C unless otherwise noted. Indoor use only.

Parameter	Conditions/Notes	Min	Typ.	Max	Units
LAN Pins	Compatible with IEEE 802.3u standard				

Table 11: Operating specifications

### Typical Performance Details

Specifications are valid at 25°C unless otherwise noted. Indoor use only.

<sup>2</sup> POE power output has a relation to system thermal characteristics shown in performance characteristics. Compatible with IEEE 802.3bt standard.

## Mechanical

3D CAD models available from <https://acroname.com>.

Figure 12: USBExt3c Mechanical Drawing

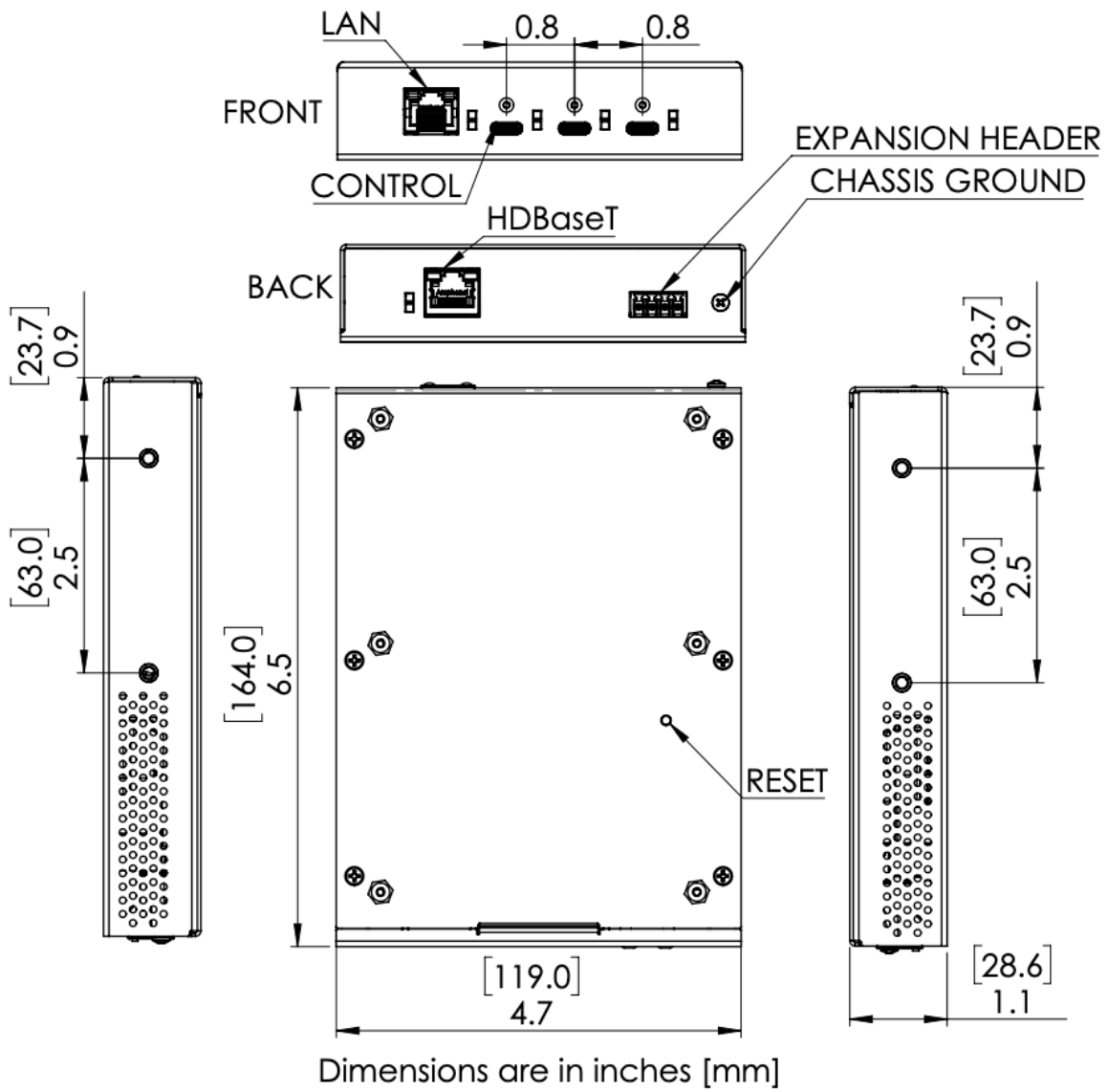

## Mounting Accessories

Two sets of mounting holes are provided for mounting the USBExt3c to tables or DIN rail. Acroname can provide mounting options as shown below:

Accessory mounting holes are present on each side of the case.  
Case threads are M4x0.7.  
Screws connecting to the case must be no longer than 8mm.

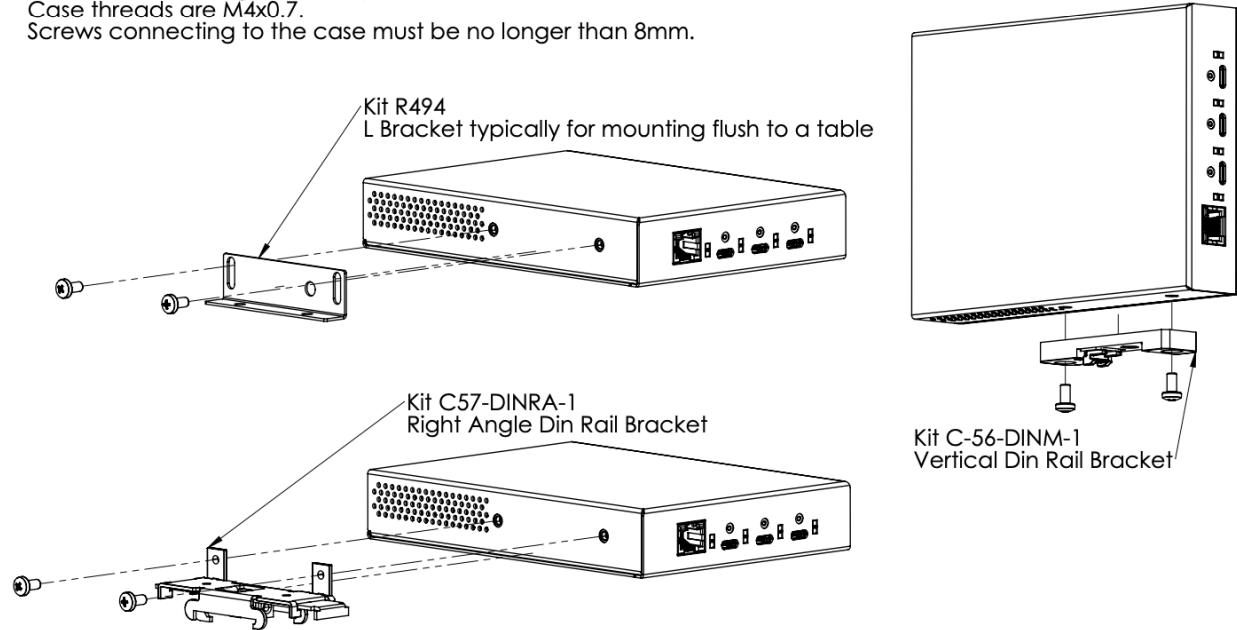

Figure 13: USBExt3c DIN Rail Mount

## Markings

Symbol	Description
	LAN Port
	Chassis ground
	GND return

Table 12: Case Symbol Markings

## FCC Compliance Statement

This equipment has been tested and found to comply with the limits for a Class B digital device, pursuant to part 15 of the FCC Rules. These limits are designed to provide reasonable protection against harmful interference in a residential installation. This equipment generates, uses and can radiate radio frequency energy and, if not installed and used in accordance with the instructions, may cause harmful interference to radio communications. However, there is no guarantee that interference will not occur in a particular installation. If this equipment does cause harmful interference to radio or television reception, which can be determined by turning the equipment off and on, the user is encouraged to try to correct the interference by one or more of the following measures:

- Reorient or relocate the receiving antenna.
- Increase the separation between the equipment and receiver.
- Connect the equipment into an outlet on a circuit different from that to which the receiver is connected.
- Consult the dealer or an experienced radio/TV technician for help.

This device complies with part 15 of FCC Rules. Operation is subject to the following two conditions; (1) This device may not cause harmful interference, and (2) this device must accept any interference received, including interference that may cause undesired operation.

## Compliance Information

BSMI EMC Class A

警告使用者:

這是甲類資訊產品，在居住環境使用時，可能會造成射頻干擾，在這種情況下，使用者會被要求採取某些適當的對策。

設備名稱： USB-C-Switch-Pro Equipment name 型號（型式）：S105-USBC-SWITCH-PRO Type designation (Type)						
單元Unit	限用物質及其化學符號 Restricted substances and its chemical symbols					
	鉛Lead (Pb)	汞Mercury (Hg)	鎘Cadmium (Cd)	六價鉻 Hexavalent chromium (Cr <sup>+6</sup> )	多溴聯苯 Polybrominate d biphenyls (PBB)	多溴二苯醚 Polybrominate d diphenyl ethers (PBDE)
機殼 Chassis	○	○	○	○	○	○
電路板 PCB Board	○	○	○	○	○	○
連接器 Connector	○	○	○	○	○	○
電子元件 Electronic Component	○	○	○	○	○	○
備考1. “超出0.1 wt %” 及 “超出0.01 wt %” 係指限用物質之百分比含量超出百分比含量基準值。 Note 1 : “Exceeding 0.1 wt %” and “exceeding 0.01 wt %” indicate that the percentage content of the restricted substance exceeds the reference percentage value of presence condition. 備考2. “○” 係指該項限用物質之百分比含量未超出百分比含量基準值。 Note 2 : “○” indicates that the percentage content of the restricted substance does not exceed the percentage of reference value of presence. 備考3. “-” 係指該項限用物質為排除項目。 Note 3 : The “-” indicates that the restricted substance corresponds to the exemption.						

## Product Support

Questions about the product operation or specifications are welcome through Acroname's contact portals. Software downloads, reference API and application examples are available online at:

<https://acroname.com/support>

Direct communication and additional technical support are available at:

<https://acroname.com/contact-us>

2741 Mapleton Avenue

Boulder, CO, USA 80304-3837

720-564-0373 (phone)

Acroname and BrainStem® are registered trademarks of Acroname, Inc. All other trademarks are property of their respective owners.

This datasheet is originally prepared in English. Translations of this datasheet into other languages are available as a courtesy but are prepared by machine translation. In the case of any discrepancy between languages the English version is definitive.

## Document Revision History

All major documentation changes will be marked with a dated revision code

Revision	Date	Engineer	Description
0.9	Sep 2025	RA	Pre-release
1.0	Dec 2025	ACRO	Initial Revision
1.1	Apr 2026	KSP	Compliance marking updates