



Overview

The USB-C-Switch Pro is a managed USB-C 1:4 / 4:1 port selector and multiplexer switch designed for automated device testing, validation, and A/V applications.

It supports USB4 (40 Gbps), pass-through of 240 W USB Power Delivery Extended Power Range (EPR) - including PPS and AVS - as well as up to 2 x 8K@120 Hz DisplayPort Alt mode video.

The USB-C-Switch Pro is not a hub — it directly connects and redrives signals in either direction between the port and one of four Mux ports, appearing *like a cable* to the connected devices. Data link, power negotiation, and power delivery are handled by the attached devices themselves.

Each for the four Mux ports and the Common Port can be independently switched and monitored through the HubTool application, web interface, or the multi-language BrainStem® API, providing:

- Voltage and current measurement on V_{BUS} and V_{CONN} lines
- Independent control of USB data and power connections
- Software-controlled cable orientation flip

Control connections are established through Ethernet, RS-232, I²C, or USB connections.

Applications

- USB-PD EPR validation and interoperability testing including Dual Role Data (DRD) and Dual Role Power (DRP) devices
- USB-C end-product testing, firmware loading, and debugging

- Conference Room USB + DisplayPort switching solutions
- Automotive head unit testing and development (supports Apple CarPlay™ and Android Auto™)
- USB-C device bring-up and verification
- USB-PD, USB4 SBU, and DisplayPort AUX signal debugging

Functions

Data

- USB4 (40 Gbps), USB 3.2 Gen2 (10 Gbps) and USB 2 switching.
- DisplayPort 2.1 Alt Mode routing (1-4 lanes, UHBR20, up to 2 x 8k@120Hz)
- USB-PD, SBU, and DisplayPort Aux message logging, decoding, and injection

Power

- Supports PD EPR up to 240 W including PPS and AVS
- Per-port voltage and current measurements:

Common Port	$V_{BUS, CC1, CC2}$	V / I
	SBU1, SBU2	V
Mux & Control Ports	V_{BUS}	V / I
	CC1, CC2	V

- Keep-Alive Charging (KAC) power on inactive ports

Control & Automation

- BrainStem® API for Python, C++, .NET, and LabVIEW
- HubTool GUI for manual operation and logging
- Manual or automatic port switching
- Independent control and split routing to any Mux port of: High Speed (HS), SuperSpeed (SS), CC / VCONN, SBU, and V_{BUS} lines
- USB-C cable flip emulation and detection with auto-flip

Hardware Features

- Active SuperSpeed redrivers on Common and Mux ports for loss compensation
- ±15kV ESD protection (IEC61000-4-2 level 4)
- Powered via Control Port or 12 V DC input (pluggable Euro-style terminal block included)
- DIN-rail mountable with optional kit
- Screw retention on all USB-C, DC power, and external IO ports
- Full control via USB Control port, Ethernet, I²C, RS-232, or port selection via GPIO

Block Diagram

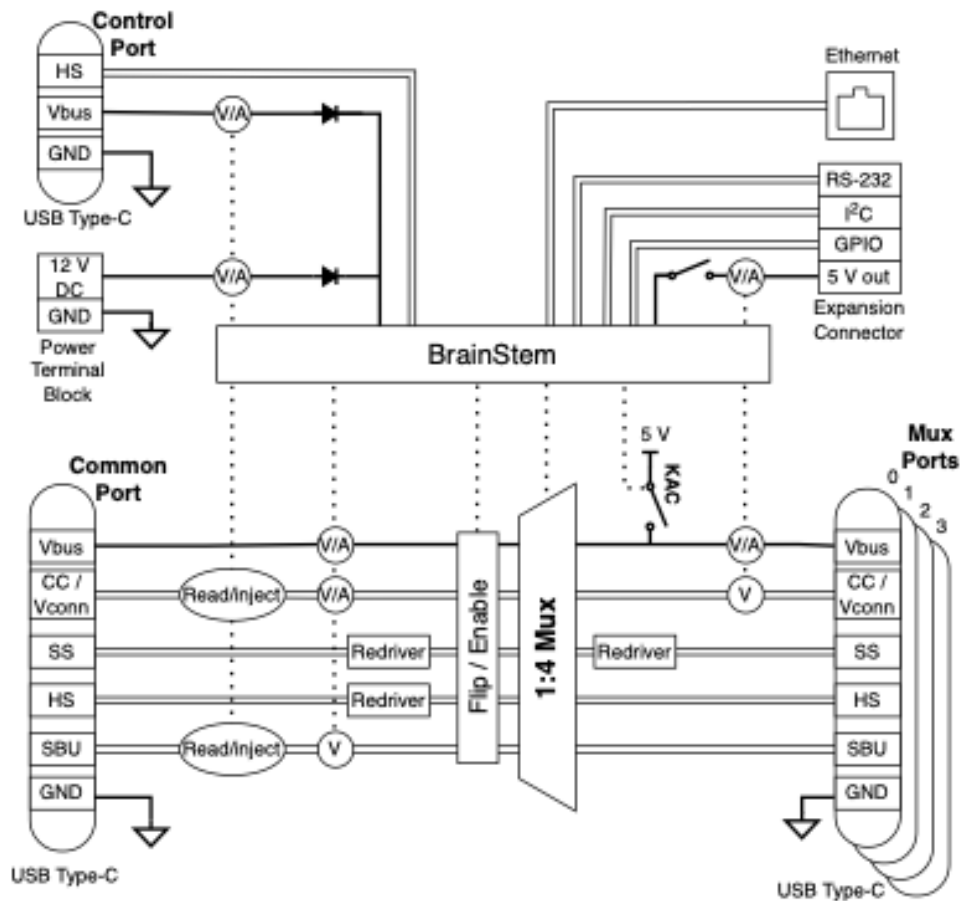

Figure 1: USB-C-Switch Pro functional block diagram

Warnings

Match EPR cables: When using EPR-capable cables, always ensure that both cables in a host-device connection support 240 W. This is because EPR sources are unaware of the distal cable and will provide power based on the e-marker of the proximal cable only.

No USB-C Audio Adapter Accessory Mode (AAAM) Support: USB AAAM is a deprecated mode that allowed analog audio signal output through a USB-C port. This mode is not supported and **can damage the USB-C-Switch Pro**.

Application Diagrams

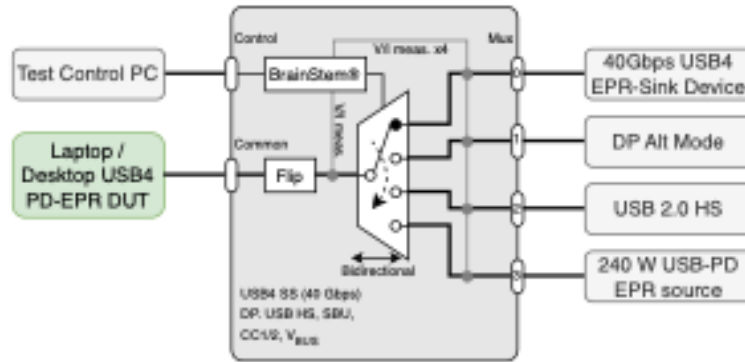

Figure 2: Typical testing application for validation against multiple types of devices

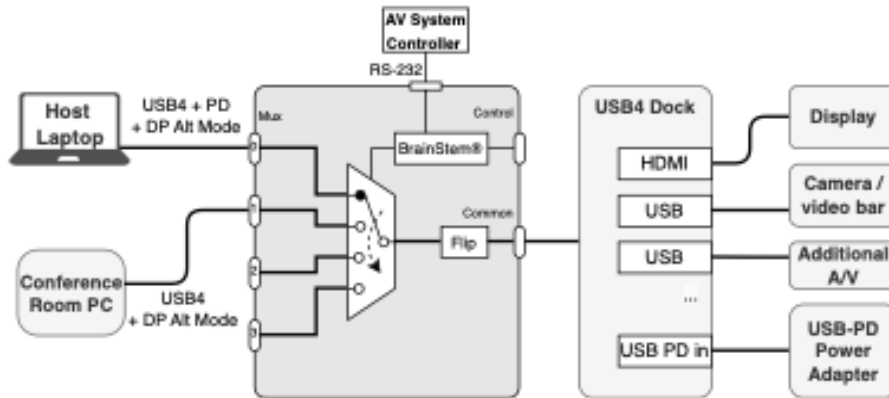

Figure 3: Automatic A/V Host switching with DP Alt Mode

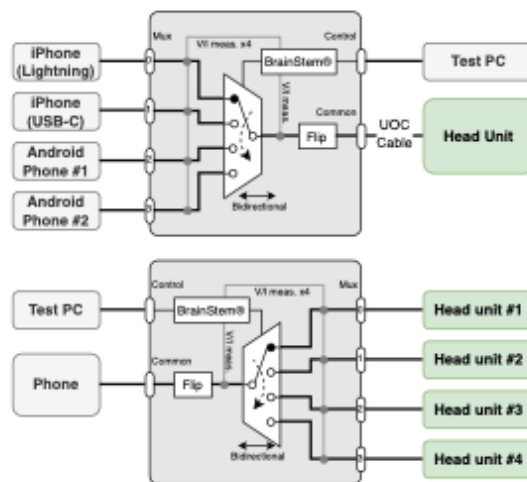

Figure 4: Android Auto / CarPlay development system

Feature Description

The USB-C-Switch Pro includes six USB-C ports: one **Common port**, four **Mux Ports**, and a dedicated **Control Port**. Software control manages signal routing and port-level functions. Each USB-C-Switch Pro is addressable and controllable via USB (Control Port), Ethernet (TCP/IP), or RS-232. Once connected, a BrainStem® link is established to the onboard controller, enabling full software control through the BrainStem® API.

USB Ports

The Common and Mux ports of the USB-C-Switch Pro implement separate, independently switched USB HS and SS data, CC, V_{CONN} and V_{BUS} lines. USB power, HS data and SS data can be independently disconnected for advanced USB testing applications. The USB-C-Switch Pro has a dedicated control channel on the Type C connector labeled “Control”. This is a high-speed USB 2.0 connection for BrainStem® interface and device power only. No other USB traffic can flow on this connection.

Table 1: USB Port Indices

Port	Index
Mux 0-3	0-3
Common	4
Control	5

Cable Orientation

A key feature of USB-C is its reversible connector, allowing insertion in either orientation. In a standard USB-C cable, only one of the CC lines and one HS pair are wired through. Orientation is defined by the male plug, which connects only one of the receptacle’s two CC (Configuration Channel) pins through the cable. The connected device detects which CC pin is active and routes signals accordingly.

In normal operation, standard USB cables on the Mux and Common sides of the Switch need to be **in the same orientation** - you may need to flip one of the cables to enable the connection.

Cable Flip

In typical operation, the USB-C-Switch Pro connects signals directly from the Common port to the active Mux port — side A to A and side B to B. The switch can also invert this mapping programmatically, rerouting CC / V_{CONN} , SBU, and USB 2/3 data lines so that **side A of the Common port** connects to **side B of the Mux port** (and vice versa). This “cable flip” operation emulates physically reversing the connection between Common and Mux ports.

When used with an Acroname Universal Orientation Cable (UOC), cable flip enables automated testing of both sides of a USB port.

Figure 5 shows example block diagrams of the flip feature when connecting a host through a standard full-featured, non-e-marked cable to a direct-connected downstream device. USB SS, HS and SBU lines are also routed, but omitted from the diagram for clarity.

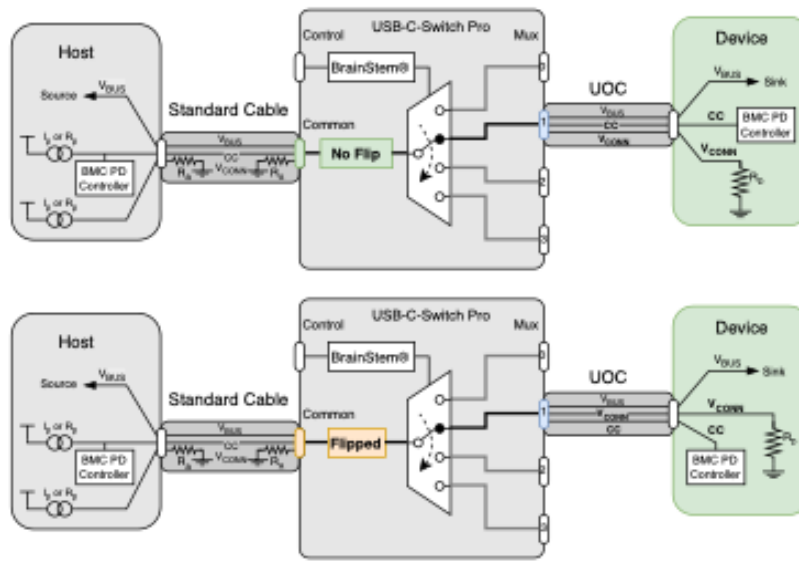

Figure 5: Flip and no-flip setting for full-featured cable and device

The UOC should be connected to the device under test and either the Common port or Mux port, depending on whether the DUTs or testers are being multiplexed.

UOC Selection

Device USB-C ports either **short** sides A and B USB 2.0 (HS) data lines or use a **mux** to keep the two sides electrically independent. Choose the UOC that matches your DUT port.

Two UOC cable types are included:

C70: routes both CC lines and **two HS pairs**, for devices with **muxed USB 2.0 sides**

C67: routes both CC lines and **one HS pair**, for devices with **shorted USB 2.0 sides**

When using C67, it may be necessary to flip the cable at the Switch end to establish a USB 2 connection.

Alt-Mode Configurations

For Alt-modes, the pin mappings and directions may affect connectivity and functionality. In many cases, the connected devices will simply negotiate through the switch. However, when using DisplayPort Alt Mode, USB4, or ThunderBolt 3, some functional groups need to be assigned a specific direction.

In HubTool:

- If device V_{BUS} is not active, toggle cable flip or check cable orientations
- Under Alt Mode, select the corresponding configuration depending on whether the host is on the Common or Mux port and the protocol used. For 2-lane DP and USB4 / TB, it may be necessary to try the inverted and non-inverted option.

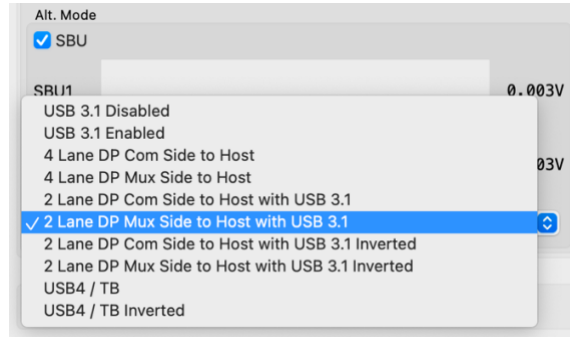

Figure 6: Alt-mode configuration menu in HubTool

Keep-Alive Charging (KAC)

It is common to use battery powered devices on the Mux or Common ports of the USB-C-Switch Pro. When these devices are not in the active path, they may go into low-power or sleep mode, or the battery may discharge. The USB-C-Switch Pro has the unique feature of Keep-Alive Charging (KAC) to provide power to the inactive Mux port connections.

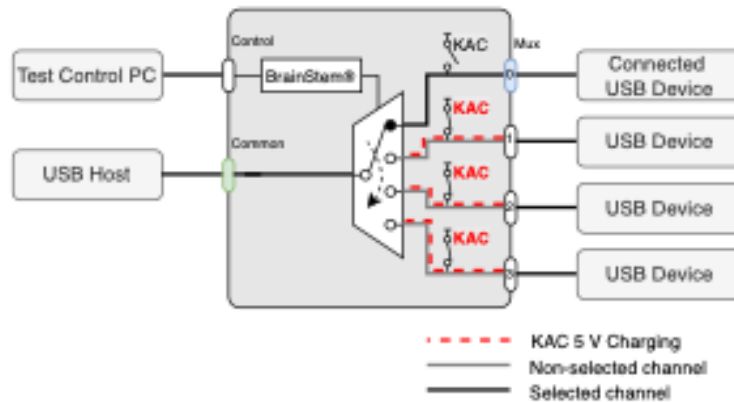

Figure 7: Typical example of KAC charging

When KAC is enabled on an inactive Mux port, the port's V_{BUS} connects to the KAC circuit to provide 5 V at 500 mA. The KAC circuit does not provide USB power-delivery (USB-PD), USB battery charge specification (BC1.2) or QuickCharge® to the selected ports. The KAC circuit has thermal and overcurrent protection and will stop providing power if limits are exceeded. KAC must be disabled and re-enabled to restore charging. KAC is automatically disabled when mux split mode is enabled. KAC is only available when providing the unit external power on the DC input.

Mux Split Mode

The default behavior of the USB-C-Switch Pro is to act as a port selector, where all USB-C lines are connected between the common port and one selected mux port. In some cases, it is desirable to split the connections in a USB-C cable and route them to different mux paths.

CAUTION: Split mode can create connections and configurations not possible or compliant with standard USB equipment. Using this feature could cause unexpected voltages to be applied to devices which may damage connected equipment.

Signal groups under Split control assignment are:

V_{BUS}
SS (TX 1/2 +/-, RX 1/2 +/-)
HS (D+/-)

CC1, CC2, SBU1, SBU2

Split mode gives control over individual signal groups, allowing each common port signal group to be independently connected to a single mux port. CC and V_{BUS} can be additionally connected to any combination of mux ports or disabled per-port.

Common applications include:

- Providing a data connection between a USB device the host machine while connecting V_{BUS} charging from a dedicated charger on a different port.
- Splitting USB HS and SS lines to provide two independent device connections to a single host port.

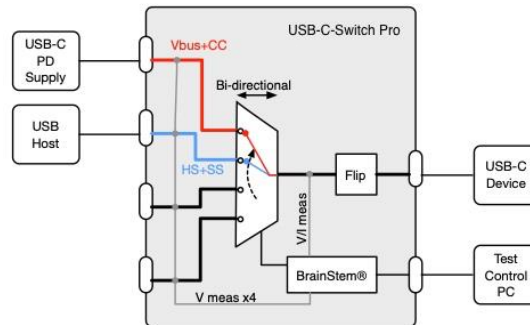

Figure 8: Adding USB-C PD charging capability to a legacy USB host output

When split mode is enabled, V_{BUS} can be assigned to multiple Mux ports simultaneously, which is useful for powering multiple devices. However, Acroname recommends that V_{BUS} be assigned to only one Mux port. Caution should be used with multi-point V_{BUS} assignments as it is possible to apply a V_{BUS} voltage to a device that has not negotiated for high V_{BUS} voltages which could damage connected devices.

When split mode is enabled, USB-C-Switch Pro will automatically disable the Keep-Alive-Charging (KAC) feature.

Ethernet Control

The USB-C-Switch Pro can be managed over Ethernet using the HubTool application, BrainStem® API, REST interface, or built-in web interface. Connections are made through the Ethernet jack using TCP/IP sockets and are supported on the local link segment only. For most setups, we recommend a direct Ethernet link between the host test machine and the USBExt3c.

By default, the USB-C-Switch Pro acts as a DHCP client and will receive an IP address from a DHCP server. If no server is detected, the USB-C-Switch Pro falls back to a static IP address of **192.168.44.42**. In static mode, the host computer interface IP must be set to an address in the **192.168.44.x** range. The DHCP client is limited to hosts on the local link and does not operate across network bridges or gateways.

The USB-C-Switch Pro responds to ICMP “ping” requests including broadcast pings. The BrainStem® API interface performs a discovery process prior to establishing communication by sending a UDP multicast request on port 9888. The USB-C-Switch Pro responds with a message to UDP port 9889. The USB-C-Switch Pro listens for socket connections on TCP port 8000. The Rest interface uses TCP on ports 9005 and 9006

Host firewall rules must allow:

- Outgoing UDP multicast on port 9888
- Incoming UDP responses on port 9889
- Outgoing TCP connections to port 8000
- Incoming / Outgoing TCP connections on ports 9005 and 9006

Indicators and Connections

Front Panel

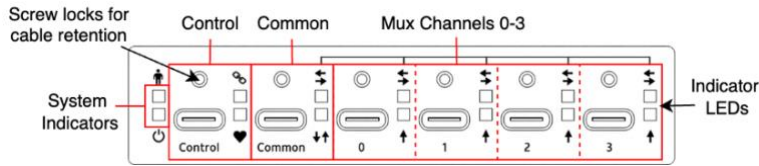

Figure 9: Front panel features

The USB-C-Switch Pro front panel contains all USB ports: Control, Common, and Mux 0-3, along with port and system LED indicators. The control port supports USB Type C power at 5 V, 3 A.

Rear Panel

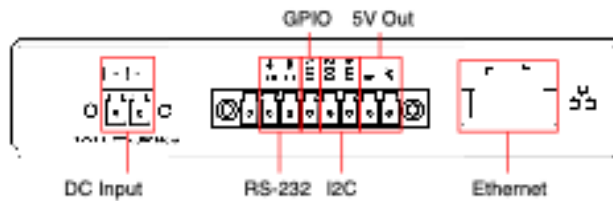

Figure 10: Rear panel features

The rear panel contains the Input Power Connector, Ethernet port, and the Expansion Connector.

Input Power Connector

Power for the USB-C-Switch Pro can be provided by the V_{BUS} line on the control port or by external power on the rear panel connection, V_{INPUT} . A Euro-style 2-pin terminal block (Phoenix Contact 1803578) is used for the external power connection, with pin spacing of 3.81mm (0.150”).

Expansion Connector

The USB-C-Switch Pro expansion connector is Euro-style 8-pin terminal block (Phoenix Contact 1847181) with pin spacing of 3.50 mm (0.138”). This interface provides additional mechanisms for expandability and test scenarios. Rail 0 is a software-controlled current-limited fixed 5V source (disabled by default). IO1 is a general-purpose input and output that can also be configured as a selector to cycle through Mux ports.

Connection Name	Pin Number	Description
GND	1	Ground
RX	2	RS-232 Serial Receive (data to USB-C-Switch Pro)
TX	3	RS-232 Serial Transmit (data from USB-C-Switch Pro)
IO1	4	General Purpose Input/Output/Selector
IO2	5	I ² C SDA
IO3	6	I ² C SCL
GND	7	Ground
5V (Rail 0)	8	Current-limited 5 V source

Table 2: Expansion Connector Pinout

LED Indicators

On the front side of the USB-C-Switch Pro there is a set of indicators that show control information and connectivity status.

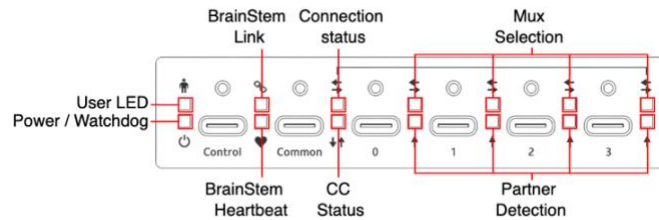

Figure 11: LED Indicators

The meaning and location of each LED are described in the following table.

Type	Icon	LED Name	Color	Description
System	Person	User LED	Blue	User-controllable LED
	Power Icon	Power/Watchdog	Red / Magenta	Alternating Red and Magenta when powered
Control	Chain Links	BrainStem® Link	Yellow	Link present
	Heart	BrainStem® Heartbeat	Green	Blink when Heartbeat received
Common	Left / Right Arrow	Connection Status Solid = connected	Green Yellow	Unflipped Flipped
	Up / Down Arrow	Partner Detection	Green	V _{BUS} present or PD negotiated
Mux Ports	Left/Right Arrow	Mux Selection: Solid = enabled Blinking = disabled	Blue Yellow	Channel selected Split mode
	Up Arrow	Partner Detection	Green	V _{BUS} present or PD negotiated
Ethernet	Left LED	Ethernet Activity	Green	Blinks with Ethernet activity
	Right LED	BrainStem® Link	Amber	BrainStem® connection established

Table 3: Indicator LED colors and descriptions

Unit Reset

The USB-C-Switch Pro can be reset to factory default settings using the reset button on bottom of the unit. Pressing the reset button once will restart the USB-C-Switch Pro as if it had been power cycled. To restore factory default settings, press twice within 5 seconds.

Device Drivers

The USB-C-Switch Pro leverages operating system user space interfaces that do not require custom drivers for operation on all modern operating systems including Windows, Linux and MacOS X. With a connection between a host PC and the USB-C control port, the host PC will recognize a USB 2.0 high-speed device named "USBCSwitchPro".

Legacy operating systems like Windows 7 may require the installation of a BrainStem® USB driver. Details on installing USB drivers can be found within the BrainStem® Development Kit under the "drivers" folder.

Programming Interface

The USB-C-Switch Pro is built on Acroname's BrainStem® platform which provides simple high-level APIs, a real-time embedded runtime engine, and modular expandability. Details of the API functionality unique to the USB-C-Switch Pro are described in the [USB-C-Switch Pro Module Entities page](#).

Pinouts and Connectivity

USB Type-C Connector Overview

The USB-C-Switch Pro uses standard USB pin-outs for the Type-C receptacles shown in Figure 12. The side-A and side-B USB HS D+ and D- are separately passed through the USB-C-Switch Pro. The Common port to Mux port pin mapping for normal and flip modes is shown in Figure 13.

A1	A2	A3	A4	A5	A6	A7	A8	A9	A10	A11	A12	 Receptacle (Front View)
GND	TX1+	TX1-	VBUS	CC1	D+	D-	SBU1	VBUS	RX2-	RX2+	GND	
GND	RX1+	RX1-	VBUS	SBU2	D-	D+	CC2	VBUS	TX2-	TX2+	GND	
B12	B11	B10	B9	B8	B7	B6	B5	B4	B3	B2	B1	

Figure 12: USB type-C receptacle pin-out

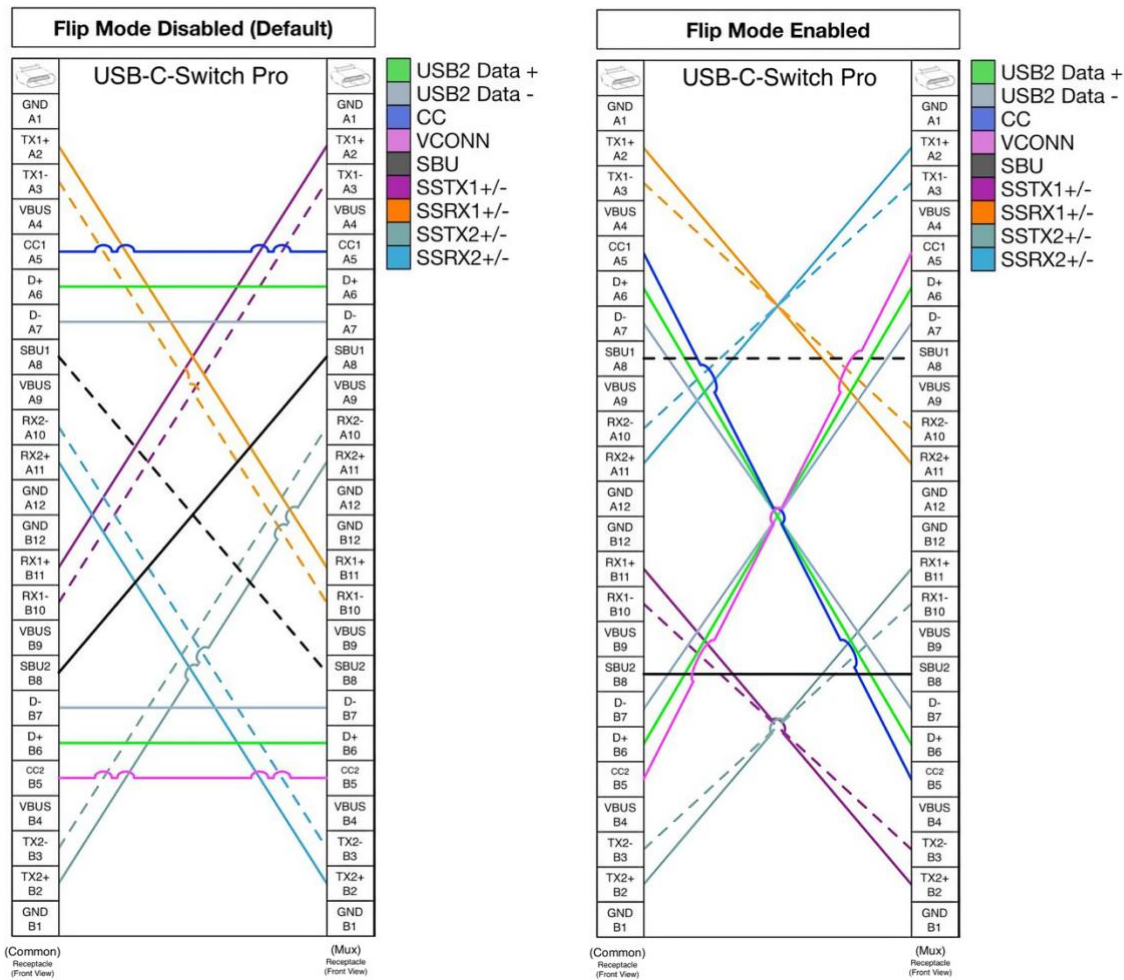

Figure 13: Common-to-Mux port pin mappings

Absolute Maximum Ratings¹

Stresses beyond those listed under ABSOLUTE MAXIMUM RATINGS can cause permanent damage to the device. These are stress ratings only and functional operation of the device at these or any other conditions beyond those indicated under RECOMMENDED OPERATING CONDITIONS is not implied. Exposure to absolute-maximum rated conditions for extended periods affects device reliability and may permanently damage the device.

Parameter	Minimum	Maximum	Units
Input voltage on V_{INPUT}	-32	32	V
Input power on V_{INPUT}	-	36	W
Input voltage on V_{BUS} control port pin	-0.3	5.5	V
Input voltage on CC control port pin	-0.3	5.5	V
Voltage on Common and Mux V_{BUS} pins	-0.3	60	V
Voltage on Common and Mux CC pins	-0.3	60	V
Voltage on any USB Super Speed (SS) pin	-0.3	60	V
Voltage on any USB High Speed (HS) pins	-0.3	4.0	V
Voltage on any SBU pins V_{BUS} current (bidirectional)	-0.3	4.0	V A
Amperage on V_{BUS}	-5.5	5.5	A
Amperage on CC	-1.2	1.2	A
Voltage on IO1-3	-0.3	25	V
Voltage on RS232 TX	-13.2	13.2	V
Voltage on RS232 RX	-25	25	V
Voltage on Rail0	-0.3	25	V
Current on Rail0	-	1.5	A
Voltage on Ethernet pins	-	60	V
Altitude	-	2000	m
Mass	-	0.4	kg

Table 4: Absolute maximum ratings

Recommended Handling Ratings

Parameter	Conditions/Notes	Minimum	Typical	Maximum	Units
Relative Humidity Range	Non-Condensing	5	-	95	%RH
Storage temperature, T_{STG}		-10.0	-	85.0	°C
Electrostatic discharge, V_{ESD}	Exceeds IEC 61000-4-2, level 4, air-discharge	-15	-	+15	kV
	Exceeds IEC 61000-4-2, level 4, contact-discharge	-8	-	+8	kV

Table 5: Handling ratings

¹ If the equipment is used in a manner not specified by the manufacturer, the protection provided by the equipment may be impaired.

Recommended Operating Ratings

Specifications are valid at 25°C unless otherwise noted. Indoor use only.

Parameter	Conditions/Notes	Minimum	Typical	Maximum	Units
Ambient operating temperature, T _A	Using external DC input	0	25	40	°C
	Using USB-C power	0	25	50	°C
Relative Humidity Range	Non-Condensing	5	-	80	%RH
Input voltage on V _{INPUT}		9	12	28	V
Input voltage on V _{BUS} control port pin		4.5	5.0	5.5	V
Voltage on any Mux Channel V _{BUS} pin		0.0	-	52.8	V
V _{BUS} current	Common & Mux connectors	-5	-	+5	A
Voltage on SS data pin	Common mode	0.0	-	2	V
	Differential	0.0	-	1.8	V _{pp}
Voltage on any HS data pin		0.0	-	3.6	V
Voltage on any SBU pin		0.0	-	3.3	V
Voltage on any CC pin		0.0	-	5.0	V
CC Current	Common & Mux connectors	-1.0	-	1.0	A
IO2-3 Voltage (I ² C)		0	3.3	3.5	V
RS232 Voltage		-12	-	12	V
RS232 Baudrate		0	115200	1000000	Baud
I ² C Bitrate		100		1000	Kbps
Ethernet Voltage			0		V
Ethernet Link speed		10	-	100	Mbps
MIPI UART		0	115200	1000000	Baud
MIPI JTAG		0			Hz
MIPI Voltage Range		0.8	-	3.3	V

Table 6: Recommended operating ratings

Typical Performance Characteristics

Specifications are valid at 25°C unless otherwise noted. Indoor use only. Sample rates are typically limited by the USB throughput of the host operating system except where bulk capture is supported.

This table is preliminary and subject to change

Parameter	Conditions/Notes	Minimum	Typical	Maximum	Units
V _{BUS} Common to Mux port ON resistance		30	35	45	mΩ
V _{BUS} current measurement		-	0.25	-	mA
V _{BUS} current measurement accuracy		-0.3	-	0.3	%FSR
V _{BUS} current measurement range		-8.192	-	8.192	A
V _{BUS} voltage measurement		-	1.29	-	mV
V _{BUS} voltage measurement		-0.3	-	0.3	%FSR
V _{BUS} voltage measurement range		0	-	85	V
CCx current measurement		-	31	-	μA
CCx current measurement accuracy		-0.5	-	0.5	%FSR
CCx current measurement range		-1	-	1	A
CCx voltage measurement		-	488	-	μV
CCx voltage measurement		-0.2	-	0.2	%FSR
CCx voltage measurement range		0	-	32	V
Keep-alive charge (KAC) voltage	Sourced from V _{input}	4.5	5.2	5.5	V
Keep-alive charge (KAC) current limit	Constant current mode short circuit to ground	-	900	-	mA
Rail0 Voltage		4.5	5.2	5.5	V
Rail0 Current Limit		-	1.44	-	A
IO1 Input Voltage Low V _{IL}	Valid input low	-	-	3.0	V
IO1 Input Voltage High V _{IH}	Valid input high	3.6	-	-	V
IO1 Output Voltage Low V _{OL}	Without external pull-up	-	0.7	-	V
IO1 Output Voltage High V _{OH}	Without external pull-up	-	5.2	-	V
CC common to Mux port DCR	A5 to A5, A5 to B5, B5 to B5	-	1.0	-	Ω

Table 7: Typical performance characteristics

Timing Characteristics

This table is preliminary and subject to change

Parameter	Conditions/Notes	Minimum	Typical	Maximum	Units
SS data propagation delay		-	-	606	ps
SS data intra-pair skew		-	-	20.5	ps
SS data inter-pair skew		-	-	71	ps
HS data propagation delay		-	0.6	-	ns
SS data rate	USB 3.2 Gen 1, Gen 2, USB4 Gen 2, Gen 3 Host/Device/Cable Dependent	5	-	40	Gbps
HS data rate	USB 1.X, USB 2.0 Host/Device/Cable Dependent	1.5	-	480	Mbps

Table 8: Timing Characteristics

Mechanical

Dimensions are shown in mm [inches]. 3D CAD models available from <https://acroname.com>.

DIMENSIONS IN MM [IN]

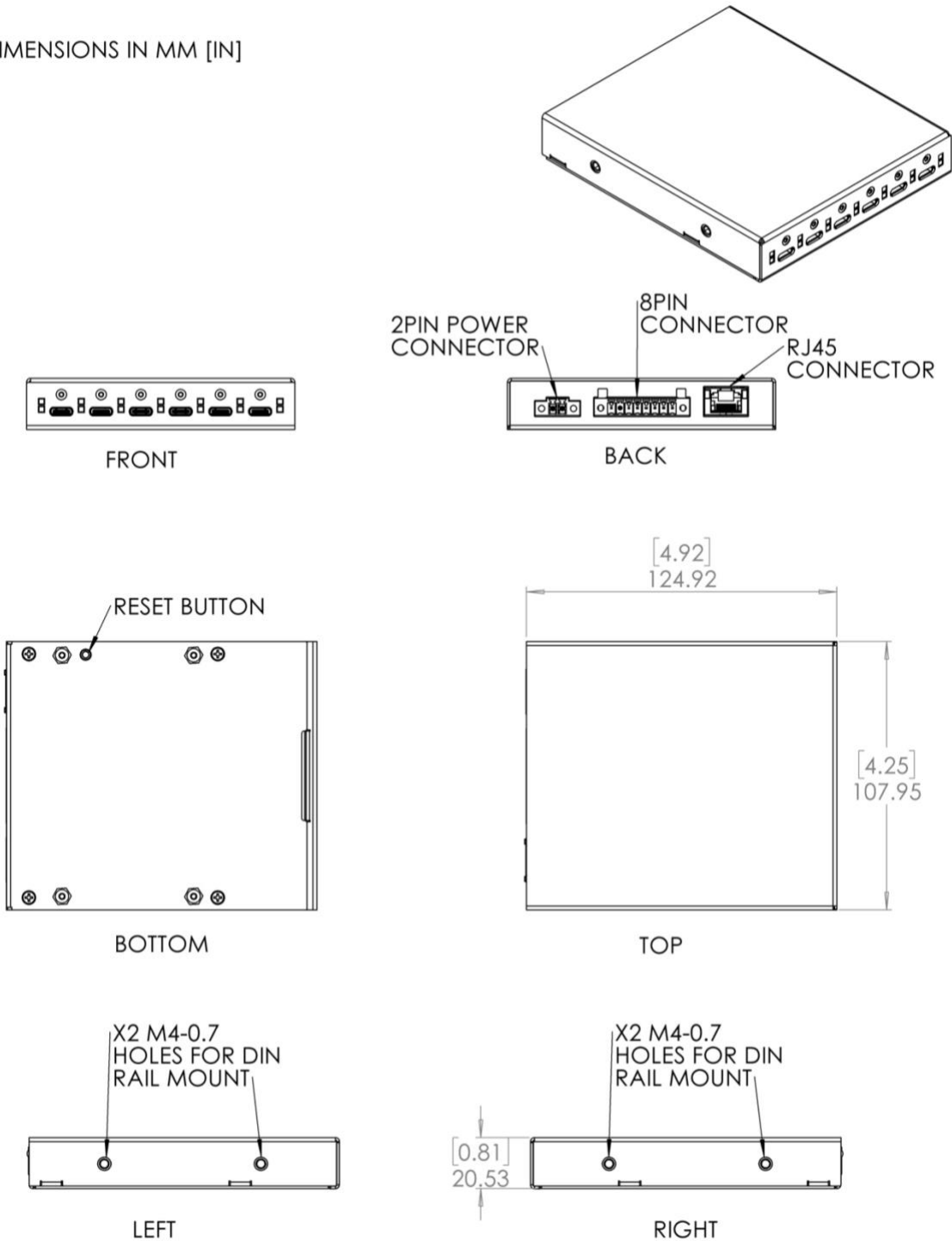

Figure 14: USB-C-Switch Pro Mechanical Dimension

Mounting

DIN rail mounting provisions have been designed into the USB-C-Switch Pro case. Holes for a DIN rail clip/adaptor are provided to allow mounting of the switch to standard DIN rails. Mounting clip hardware is available separately in a kit from Acroname: part number C56-DINM-1 or C57-DINRA-1.

The USB-C-Switch Pro can be mounted in two positions as shown in Figure 17.

Warning: Care should be taken to only use clip mounting hardware included by Acroname.

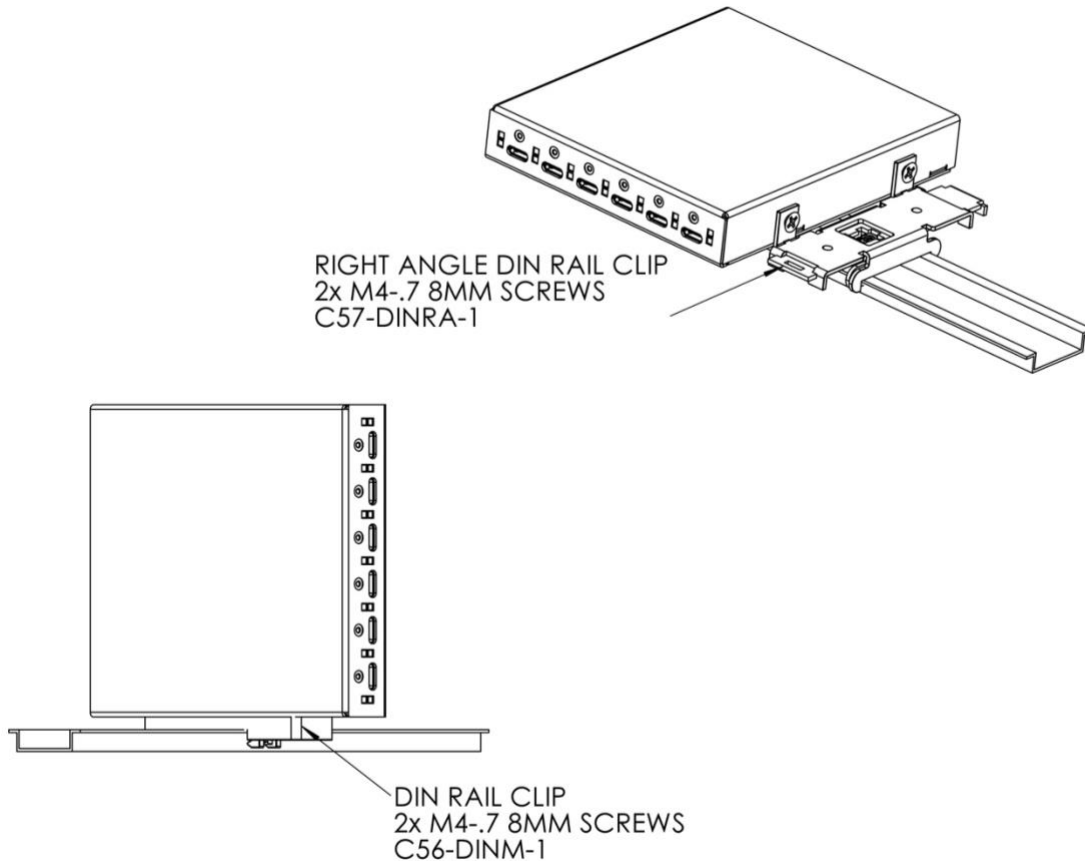

Figure 15: USB-C-Switch Pro DIN Rail mounting

Power Connection

Ensure that you have access to the power source for the USB-C-Switch-PRO once mounted. This may be either a power adapter connected to the back of the unit, or the USB-C cable connected to the control port on the front of the unit.

The DC input, via a power adapter on the rear of the unit, is a 12VDC 30W connection.

The USB-C power connection, via the marked control port of the front of the unit, is a 5V 15W connection.

FCC Compliance Statement

This equipment has been tested and found to comply with the limits for a Class B digital device, pursuant to part 15 of the FCC Rules. These limits are designed to provide reasonable protection against harmful interference in a residential installation. This equipment generates, uses and can radiate radio frequency energy and, if not installed and used in accordance with the instructions, may cause harmful interference to radio communications. However, there is no guarantee that interference will not occur in a particular installation. If this equipment does cause harmful interference to radio or television reception, which can be determined by turning the equipment off and on, the user is encouraged to try to correct the interference by one or more of the following measures:

- Reorient or relocate the receiving antenna.
- Increase the separation between the equipment and receiver.
- Connect the equipment into an outlet on a circuit different from that to which the receiver is connected.
- Consult the dealer or an experienced radio/TV technician for help.

This device complies with part 15 of FCC Rules. Operation is subject to the following two conditions; (1) This device may not cause harmful interference, and (2) this device must accept any interference received, including interference that may cause undesired operation.

Compliance Information

BSMI EMC Class A

警告使用者:

這是甲類資訊產品，在居住環境使用時，可能會造成射頻干擾，在這種情況下，使用者會被要求採取某些適當的對策。

設備名稱： USB-C-Switch-Pro ， Equipment name 型號（型式）：S105-USBC-SWITCH-PRO Type designation (Type)						
單元Unit	限用物質及其化學符號 Restricted substances and its chemical symbols					
	鉛Lead (Pb)	汞Mercury (Hg)	鎘Cadmium (Cd)	六價鉻 Hexavalent chromium (Cr ⁺⁶)	多溴聯苯 Polybrominate d biphenyls (PBB)	多溴二苯醚 Polybrominate d diphenyl ethers (PBDE)
機殼 Chassis	○	○	○	○	○	○
電路板 PCB Board	○	○	○	○	○	○
連接器 Connector	○	○	○	○	○	○
電子元件 Electronic Component	○	○	○	○	○	○

備考1. “超出0.1 wt %” 及 “超出0.01 wt %” 係指限用物質之百分比含量超出百分比含量基準值。
Note 1 : “Exceeding 0.1 wt %” and “exceeding 0.01 wt %” indicate that the percentage content of the restricted substance exceeds the reference percentage value of presence condition.

備考2. “○” 係指該項限用物質之百分比含量未超出百分比含量基準值。
Note 2 : “○” indicates that the percentage content of the restricted substance does not exceed the percentage of reference value of presence.

備考3. “-” 係指該項限用物質為排除項目。
Note 3 : The “-” indicates that the restricted substance corresponds to the exemption.

Product Support

Questions about the product operation or specifications are welcome through Acroname's contact portals. Software downloads, reference API and application examples are available online at:

<https://acroname.com/support>

Direct communication and additional technical support are available at:

<https://acroname.com/contact-us>

Acroname, Inc
2741 Mapleton Avenue
Boulder, CO, USA 80304-3837
Phone: +1-720-564-0373

Acroname and BrainStem® are registered trademarks of Acroname, Inc. All other trademarks are property of their respective owners.

This datasheet is originally prepared in English. Translations of this datasheet into other languages are available as a courtesy but are prepared by machine translation. In the case of any discrepancy between languages the English version is definitive.

Information in this document is subject to change without notice. All previous releases of this document are superseded by this release. While Acroname has made every effort to ensure the accuracy of this document, we assume no liability for inadvertent errors or omissions. Acroname reserves the right to modify, withdraw, or remove any part of this document at any time, and is not bound by or subject to conditions outlined in previous releases.

Errata

Known limitations may affect specific hardware revisions of the USB-C Switch Pro. Not all units are affected. Users should verify the hardware revision before determining whether an erratum applies.

Errata Summary

ID	Title	Affected Revisions	Status
ERR-001	USB4 / Thunderbolt / DisplayPort Flip Limitation	Rev D through F	Fixed in Rev G

Identifying the Hardware Revision

The hardware revision can be read using the BrainStem API. The returned hardware version is a 32-bit value. For the USB-C Switch Pro, one byte of this value contains the ASCII hardware revision letter.

Python Example Code:

```
import brainstem

stem = brainstem.stem.USBCSwitchPro()
stem.discoverAndConnect(1)

result = stem.system.getHardwareVersion()

if result.error == 0:
    hardware_version = chr((result.value>>24) & 0xFF)
else:
    raise RuntimeError(f"Unable to read hardware version: {result.error}")

print(f"USBCSwitchPro hardware revision: {hardware_version}")
```

ERR-001: USB4 / Thunderbolt / DisplayPort SuperSpeed Flip Limitation

Affected Hardware Revisions:

Revisions D through F are affected.

Status:

The limitation is addressed in hardware revision G.

Description:

USB-C Switch Pro hardware Revisions D through F have a limitation when using the SuperSpeed flip (SS Flip) feature with USB4, Thunderbolt, or DisplayPort traffic. Normal routing of USB-C signals through the mux operates as expected in either cable

orientation. The limitation only applies when the product is configured to cross orientations by enabling SuperSpeed flip (SS Flip). When SuperSpeed flip is enabled on affected hardware revisions, USB4, Thunderbolt, or DisplayPort links will fail to establish or operate as expected. The issue does not affect normal mux routing in either USB-C orientation and does not affect USB3.2 Gen 1 or Gen 2 flip.

Impact:

Affected setups or configurations:

- USB4 / Thunderbolt flip testing
- DisplayPort Alternate Mode video flip testing (with or without USB3 traffic)

Workaround:

Avoid using SuperSpeed flip when flip testing USB4, Thunderbolt, or DisplayPort traffic through affected hardware revisions. A potential workaround is to use two universal-orientation cables and configure the CC path so that only one CC signal is passed through the USB-C Switch Pro. This will force the attached systems into a fixed orientation on side 1 or 2 and avoid relying on the SuperSpeed flip path.



Workaround Implementation:

- Allow only one selected CC path through the switch to force a known USB-C orientation
- Do not enable the SuperSpeed flip feature via software for USB4, Thunderbolt, or DisplayPort traffic
- Route SuperSpeed lanes normally
- Note: Indirect flip testing can still be achieved by selecting either orientation via the isolated CC line

Example CC Selection:

Allows CC1 only and disables CC2, forcing orientation to side 1.

Python Example Code:

```
COMMON_PORT = 4 # USB-C Switch Pro common port

stem.port[COMMON_PORT].setCC1Enabled(True)
stem.port[COMMON_PORT].setCC2Enabled(False)
```

The selected CC line must match the intended cabling orientation and system setup. Validate the workaround with the specific host, cable, device, and operating mode.

Resolution:

This limitation is resolved in USB-C Switch Pro hardware revision G.

Revision G includes hardware changes that allow the SuperSpeed orientation flip path to support the intended USB4, Thunderbolt, and DisplayPort use cases.

Additional Notes:

The workaround guidance is provided as a general reference. Effectiveness may vary depending on the connected host, device, cable assembly, operating mode, and system configuration. Validation in the target application is recommended.

Normal SuperSpeed mux routing in either USB-C orientation is expected to operate normally. SBU1/2 or HighSpeed flip are expected to operate normally.

For additional assistance, contact Acroname support with the product model, serial number, and physical cable setup / configuration. Also provide a description of the USB4, Thunderbolt, or DisplayPort mode in use.

Document Revision History

All major documentation changes will be marked with a dated revision code

Revision	Date	Engineer	Description
0.1	May 2024	MJK	Pre-Release
0.9	August 2025	RA	Pre-Production
0.91	November 2025	RA	RC 1
0.95	January 2026	KSP	RC 2 – testing updates
0.96	April 2026	KSP	RC3 - compliance testing updates
1.0	May 2026	GF	Errata ERR-001