

ACRONAME

DIN Rail Mounting

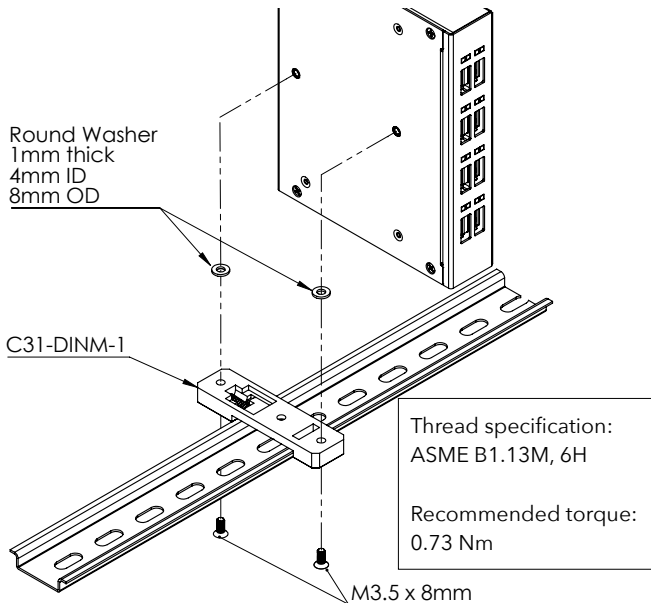

- Acroname recommends using **C31-DINM-1 Kit** as shown above
- Use only the screws and spacer washers as shown

CAUTION: Using longer attachment screws may result in damage to your product which will void your product warranty

For more information and support:
acroname.com/DINmount
support@acroname.com