



Overview

The Acroname MTM Power Module (MTM-PM-1), part of Acroname's MTM (Manufacturing Test Module) product series, is a software-controlled voltage and current limiting modular power supply, designed for MTM-based manufacturing or R&D test systems. The MTM-PM-1 allows MTM system designers to easily and modularly add power regulation and control to their test system designs.

The MTM-PM-1 provides stable, consistent and robust power to a wide range of devices and is optimized for devices using LiPo or similar batteries. Switch mode and linear mode are available, giving MTM-PM-1's ultra-fast transient response and making it ideal for use in RF noise-sensitive applications (GSM, UMTS, LTE, CDMA, etc.).

Built using Acroname's industry-proven and well-adopted BrainStem® technology, resources on the MTM-PM-1 are controlled via Acroname's powerful and extensible BrainStem® technology and software APIs.

Typical applications include:

- Manufacturing functional testing
- Validation testing
- Automated test development
- Embedded system development
- Battery emulation

Features

- 1 fully software-controllable, regulated output with ~1mV resolution, up to a 5V/3A current limit (Rail0)
- Switched and linear regulation mode stages (Rail0)
- Remote/Kelvin sense capability (Rail0)
- Rail output current voltage-mirror (Rail0)
- Rail output enable indicator (Rail0)
- 1 switched, unregulated pass-through output (from V_{supply}), with software enable and current limiting (Rail1)
- 2 overvoltage and current protected digital GPIO
- 1 BrainStem I²C FM+ (1Mbit/s) bus

- On-board local temperature sensor for monitoring and over-temperature shutdown
- Optional K-Type thermocouple input for remote sensing (ordering option)

Description

As part of Acroname's MTM series, the MTM-PM-1 is a key component for manufacturing test and R&D of devices requiring highly accurate, controllable power supply and measurement in an MTM-based test system. For more information on the MTM platform architecture, please refer to www.acroname.com.

The MTM-PM-1 implements an on-board BrainStem controller running a RTOS (Real-Time Operating System), which provides a USB host connection, independent operating capability and the BrainStem interface, for control of the MTM resources identified in this datasheet (Rail0, Rail1, GPIO, etc.).

The MTM-PM-1 provides two main power outputs. Rail0 is a fully regulated output that includes a switch-mode stage as well as a linear stage. Rail1 is an unregulated, switchable output that passes through power directly from V_{supply} . In noise-sensitive applications, the MTM-PM-1 can be operated in fully linear power supply mode; no potential RF noise from switchers. When thermal and efficiency operation is more important, utilize the first-stage, pre-conditioning switch mode power supply (SMPS) followed by the high-accuracy, ultra-fast response linear stage.

Within the MTM platform architecture, the MTM-PM-1 module can operate either independently or as a component in a larger network of MTM modules. Each MTM-PM-1 is uniquely addressable and controllable from a host by connecting via the on-board USB connection, the card-edge USB input or through other MTM modules on the local MTM/BrainStem I²C bus.

Acroname's BrainStem™ link is established over the selected input connection. The BrainStem link allows a connection to the on-board controller and access to the available resources in the MTM-PM-1. The MTM-PM-1 can then be controlled via a host running BrainStem APIs or it can operate independently by running locally embedded, user-defined programs based on Acroname's BrainStem Reflex language in the RTOS.

IMPORTANT NOTE:

The MTM-PM-1, like all MTM modules, utilizes a PCIe connector interface but is for use strictly in MTM-based systems – it should never be installed in a PCI slot of a host computer directly. Insertion into a PC or non-MTM system could cause damage to the PC.



Absolute Maximum Ratings

Stresses beyond those listed under ABSOLUTE MAXIMUM RATINGS can cause permanent damage to the device. These are stress ratings only and functional operation of the device at these or any other conditions beyond those indicated under RECOMMENDED OPERATING CONDITIONS is not implied. Exposure to absolute-maximum rated conditions for extended periods affects device reliability and may permanently damage the device.

Parameter	Minimum	Maximum	Units
Input Voltage, V_{supply}	6.0	14.0	V
Input Current, I_{supply}	0.0	14.0	A
Voltage to any IO pin	-0.5	12.5	V
Voltage to any I2C pin	0.0	5.5	V
Rail0 Thermal Shutdown	-	125	°C

Table 1: Absolute Maximum Ratings

The MTM system is designed to be used in a system where V_{supply} is the highest voltage connected to all MTM modules. Each module is designed to withstand V_{supply} continuously connected to all IOs, excepting those specified above, including accidental reverse polarity connection between V_{supply} and ground (0V). As with all products, care should be taken to properly match interface voltages and ensure a well-architected current-return path to ground. As with all devices utilizing USB interfaces, care should be taken to avoid ground loops within the USB subsystem. When using the USB interface, ground must be at 0V potential to avoid damaging connected host systems.

Handling Ratings

Parameter	Conditions/Notes	Minimum	Typical	Maximum	Units
Ambient Operating Temperature, T_A	Non-Condensing	0.0	25.0	70.0	°C
Storage Temperature, T_{STG}		-10.0	-	85.0	°C
Electrostatic Discharge, V_{ESD}	IEC 61000-4-2, level 4, contact discharge	0.0	-	±8000	V

Table 2: Handling Ratings

Recommended Operating Ratings

Values presented apply to the full operating temperature range.

Parameter	Conditions/Notes	Minimum	Typical	Maximum	Units
Input Voltage, V_{supply}		6.0	-	12.0	V

Table 3: Recommended Operating Ratings



Block Diagram

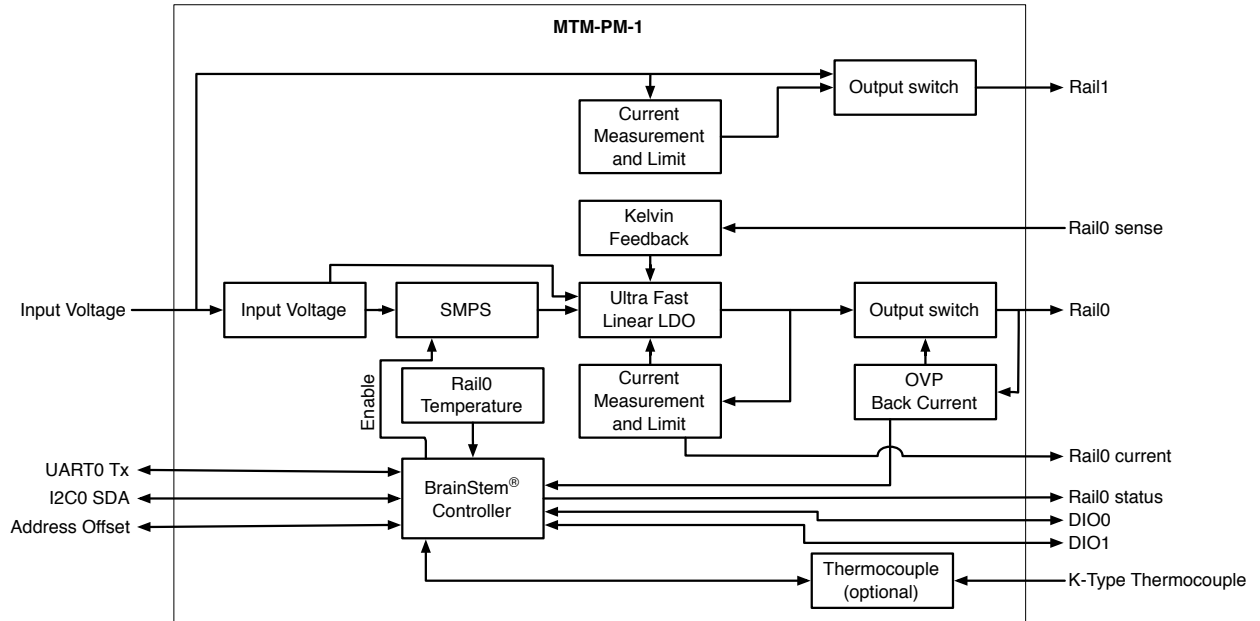

Figure 1: MTM-PM-1 Block Diagram



Typical Performance Characteristics

Values presented apply to the full operating temperature range.

Parameter	Conditions/Notes	Minimum	Typical	Maximum	Units
Base Current Consumption, I_{supply}	$V_{supply}=6V$, Not Enumerated	-	105	-	mA
	$V_{supply}=6V$, Enumerated	-	107	-	
	$V_{supply}=12V$, Not Enumerated	-	120	-	
	$V_{supply}=12V$, Enumerated	-	122	-	
Rail0 Output Voltage, V_{RAIL0}	Software controlled	1.8	-	5.0	V
Rail0 Turn-on Time		-	-	1.0	s
Rail1 Output Current Limit	Software controlled	0.001	-	3.0	A
Digital Output Drive Current	Output high; short to GND	-	20.0	30.0	mA
	Output high into 2.97V	-	3.5	-	
Digital Output Sink Current	Output low; short to V_{supply}	-	-20.0	-30.0	mA
Digital Output Short Duration	Output high	-	Infinite	-	hours
Digital Output Overvoltage	V_{supply} on pin	-	Infinite	-	hours
Digital Sample Rate ¹	Mac – OS10 (C++)	-	700	1000	Hz
	Mac – OS10 (Python)	-	640	1000	Hz
	Windows 10 (C++)	-	1000	1000	Hz
	Windows 10 (Python)	-	1000	1000	Hz
	Linux – 14.04 LTS (C++)	-	850	1000	Hz
	Linux – 14.04 LTS (Python)	-	790	1000	Hz
	Reflex	-	11000	1000	Hz
Digital Output Jitter	Using Reflex only	-	-	25	uS
	Reflex w/ BrainStem load	-	-	100	uS
Reset Low Threshold		-	1.2	-	V
I2C SDA, SCL Pins		0.0	3.3	5.5	V
UART Tx/Rx Logic High, V_{IH}	For firmware recovery	2.15	-	-	V
UART Tx/Rx Logic Low, V_{IL}	For firmware recovery	-	-	1.1	V
UART, Digital Input/Output		-	3.3	-	V
Digital Input Logic High, V_{IH}		2.15	-	-	V
Digital Input Logic Low, V_{IL}		-	-	1.1	V
Digital Input Resistance	Configuration mode set to both Input and High-Z	-	4.25	4.45	MΩ
Digital Input Leakage Current	Configuration mode set to both Input and High-Z	-	110	-	uA

¹ Host dependent, test was done as a single instruction, subsequent instructions may affect performance. Measurements taken using BrainStem Library 2.3.2. The Nyquist frequency should be considered when referring to these values.



Rail0 Thermal Shutdown		-	-	125	°C
Rail0 Thermal Shutdown Hysteresis	After thermal shutdown event	100.0	-	-	°C
Rail0 Output Voltage Ripple	Linear Mode	-	-	21	mV
Rail0 Output Voltage Ripple	Switcher Mode	-	-	31	mV
Rail0 Voltage Accuracy	150mA load	-	0.5	-	%
Rail0 Voltage Output Ripple	150mA load	-	13	20	mV
Rail0 Voltage Control Resolution		-	1.5	-	mV
Rail0 Linear-mode Drop Out		-	0.8	1.2	V
Rail0 Switcher-mode Supply	V _{supply}	7.0	-	-	V
Rail0 Thermal Drift	Full temperature range	-	-	1.5	mV
Rail0 Current Voltage-Mirror ²			1.0		V/A
Rail0 Current Mirror Zero-offset		-	15	20	mV
Rail0 Current Mirror Output Accuracy	I _{out} ≤ 500mA I _{out} > 500mA	- -	2 0.5	5 1	%
Rail0 Transient Load Response	1A step load at 5μs ³ 1A step load at 28μs ¹ 2A step load at 28μs ¹ 3A step load at 28μs ¹	- - - -	80 10 10 25	100 20 25 35	mV
Rail0 Enable Time ⁴ , 0μF ⁵	V _{rail} = 1.8V, limit=3A V _{rail} = 3.3V, limit=3A V _{rail} = 3.8V, limit=3A V _{rail} = 5.0V, limit=3A	- - - -	80 125 140 175	- - - -	μs
Rail0 Enable Time ² , 4.7μF ³	V _{rail} = 1.8V, limit=3A V _{rail} = 3.3V, limit=3A V _{rail} = 3.8V, limit=3A V _{rail} = 5.0V, limit=3A	- - - -	110 165 175 230	- - - -	μs
Rail1 On resistance (R _{on})		-	70	-	mΩ
Rail1 Enable Time, 0 uF ³		-	570	-	μs
Rail1 Enable Time, 4.7 uF ³		-	590	-	μs
Current Limit Accuracy	Limit <250mA Limit ≥250mA	- -	25 10	- -	mA %

Table 4: Typical Performance Characteristics

² Current output voltage-mirror must be connected to high impedance

³ Kelvin sense connected and enabled; 5μs is maximum voltage drop due to step load; 28μs for 3GPP reference

⁴ Rise time to within 90% of V_{rail}

⁵ Enable time depends heavily on the operational load, so the maximum rise time will be application-dependent

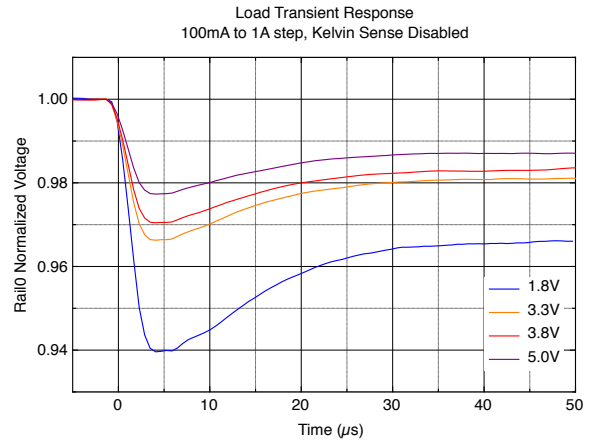
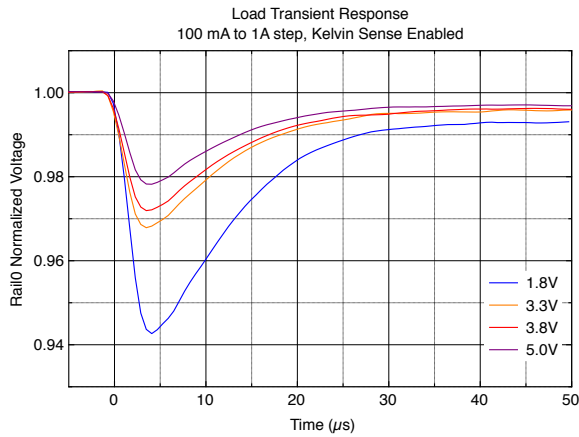
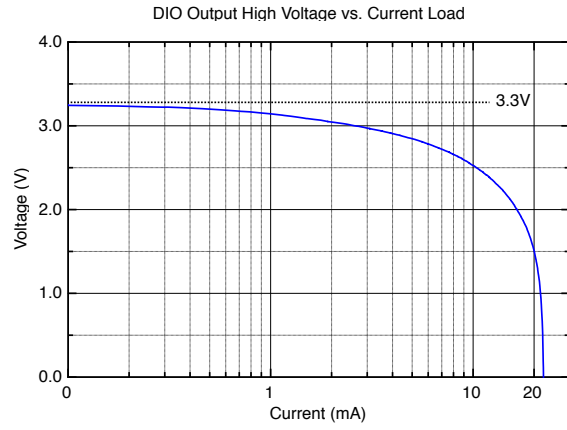
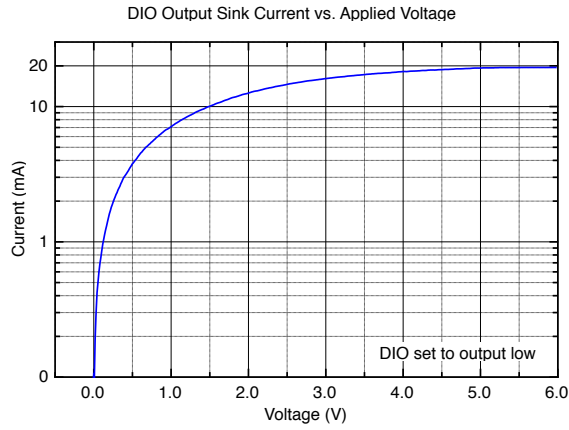

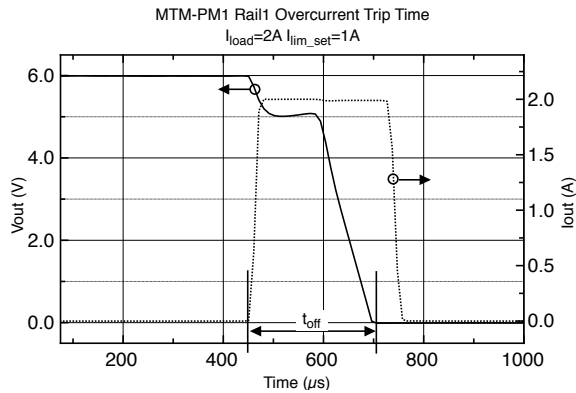
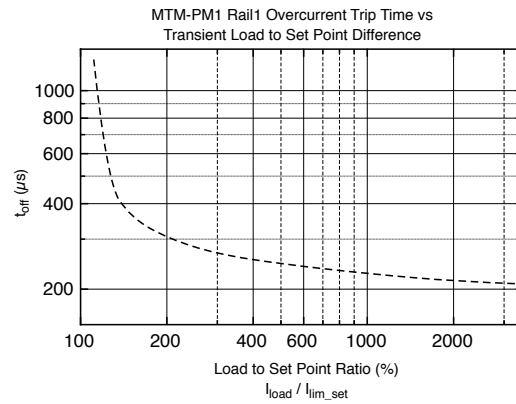
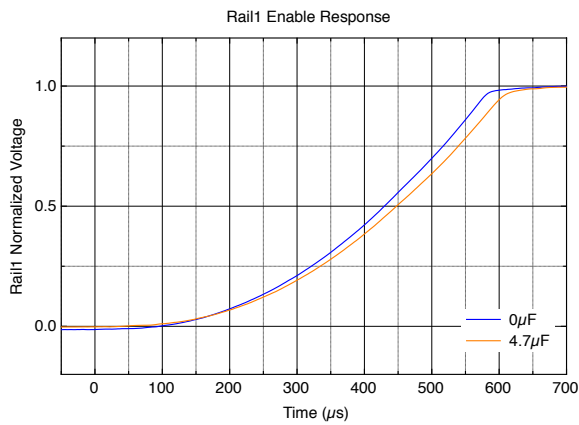
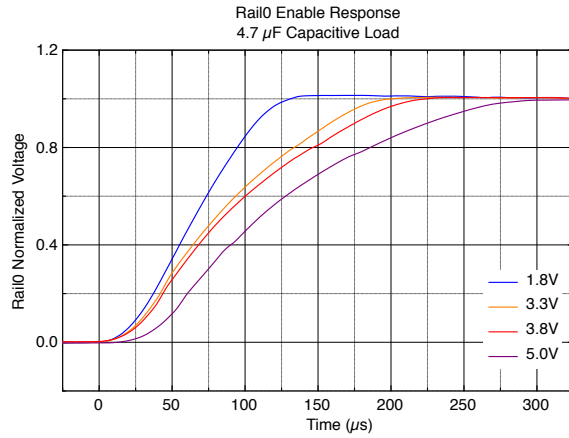
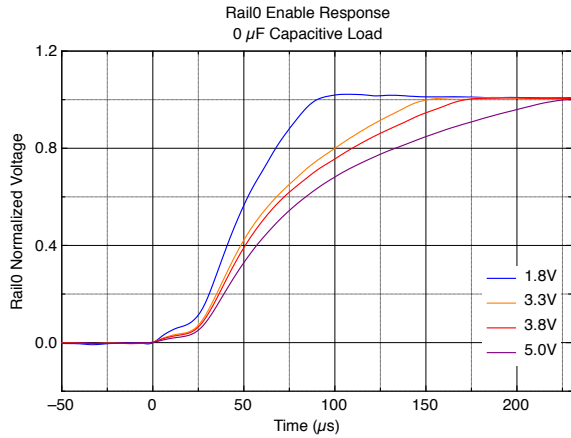



Pinout Descriptions

WARNING: Acroname's MTM line features a PCIe connector that is common in most desktop computers; however, they are NOT intended nor designed to work in these devices. Do NOT insert this product into any PCIe slot that wasn't specifically designed for this product! Failure to follow this warning WILL result in damage to this product and any device you connect it to.

The MTM edge connector pin assignments are shown in the following table. Please refer to Table 3: Recommended Operating Ratings for appropriate signal levels.

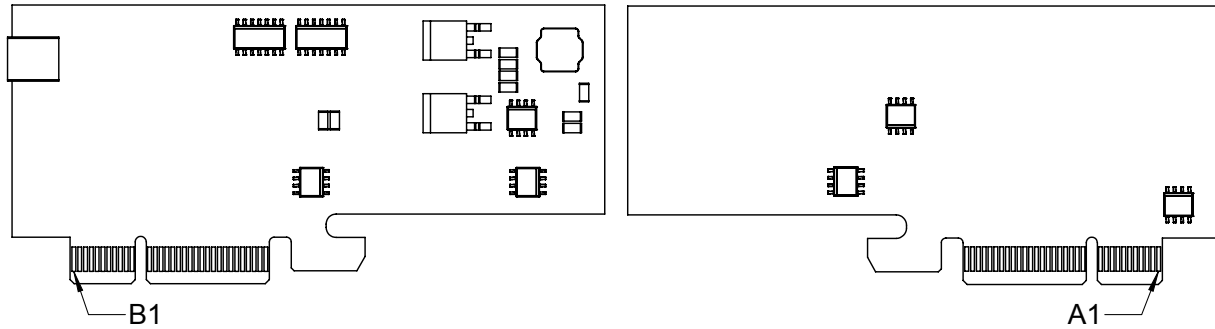

Pins Common to all MTM Modules

Edge Connector Side A	Edge Connector Side A Description	Edge Connector Side B	Edge Connector Side B Description
1	GND	1	Input Voltage, V_{supply}
2	GND	2	Input Voltage, V_{supply}
3	GND	3	Input Voltage, V_{supply}
4	GND	4	Input Voltage, V_{supply}
5	Reset	5	Input Voltage, V_{supply}
6	GND	6	Reserved, Do Not Connect
7	GND	7	Reserved, Do Not Connect
8	I ² C SCL	8	GND
9	I ² C SDA	9	GND
10	GND	10	UART0 Transmit
11	GND	11	UART0 Receive
12	Module Address Offset 0	12	Module Address Offset 2
13	Module Address Offset 1	13	Module Address Offset 3



Pins Specific to MTM-PM-1

Edge Connector Side A	Edge Connector Side A Description	Edge Connector Side B	Edge Connector Side B Description
14	Reserved, Do Not Connect	14	USB Upstream Data +
15	K-Type Thermocouple +	15	USB Upstream Data -
16	K-Type Thermocouple -	16	Reserved, Do Not Connect
17	Reserved, Do Not Connect	17	Reserved, Do Not Connect
18	RAIL0 Kelvin Sense Negative Return ⁶	18	RAIL0 Kelvin Sense Positive Return
19	GND	19	RAIL0 +
20	GND	20	RAIL0 +
21	GND	21	RAIL0 +
22	GND	22	RAIL0 +
23	Digital IO 1	23	Digital IO 0
24	RAIL0 Current Mirror (1V/1A)	24	RAIL0 Power Enable Status
25	Reserved, Do Not Connect	25	RAIL1 +
26	Reserved, Do Not Connect	26	RAIL1 +
27	Reserved, Do Not Connect	27	RAIL1 +
28	Reserved, Do Not Connect	28	RAIL1 +
29	Reserved, Do Not Connect	29	Reserved, Do Not Connect
30	Reserved, Do Not Connect	30	Reserved, Do Not Connect
31	Reserved, Do Not Connect	31	Reserved, Do Not Connect
32	Reserved, Do Not Connect	32	Reserved, Do Not Connect

⁶ RAIL0 Kelvin Sense Negative return is electrically connected to GND



Upstream USB Connectivity Options

All MTM modules with upstream USB connections (that's all MTM excluding MTM-EtherStem) have two methods for connection via USB: through the Mini-B connector, or through pins B14 and B15 of the PCIe edge connector (below). The upstream mode defaults to AUTO, which prioritizes based on the presence or absence of VBUS at the Mini-B connector.

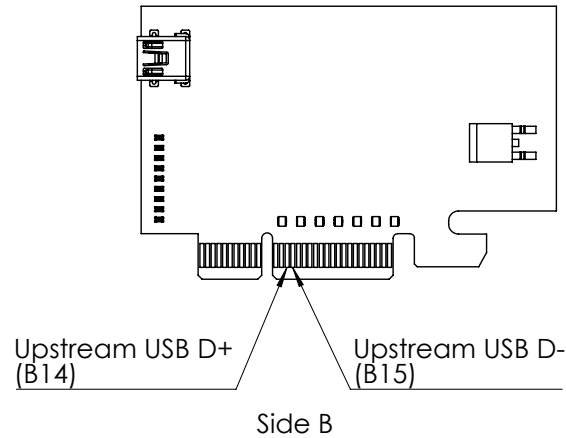



Module Hardware and Software Default Values

The MTM-PM-1 module utilizes a subset of BrainStem entity implementations that are specific to the hardware's capabilities. Table 5: MTM-PM-1 Hardware and Software Default Values details the BrainStem API entities and macros used to interface to the MTM-PM-1 module. For C and C++ developers, these macros are defined in `aMTMPM1.h` from the BrainStem development package. For Python development, the module `MTMPM1` class defines the extent of each entity array. While the BrainStem API entities define the full potential functionality of a given interface, not all features are supported by the MTM-PM-1 module. Table 5: MTM-PM-1 Hardware and Software Default Values defines each of the options implemented with each entity, which varies by entity index. Calling an unsupported entity option will return an appropriate error (e.g.: `aErrInvalidEntity`, `aErrInvalidOption`, `aErrMode`, or `aErrUnimplemented`) as defined in `aError.h` for C and C++ and the `Result` class in Python.

Parameter	Index	Macro Name or Implemented Options	Notes
Module Definitions:			
Module Base Address	6	<code>aMTMPM1_MODULE_BASE_ADDRESS</code>	See <code>aMTMPM1.h</code>
Entity Class Definitions:			
<code>digital</code> Entity Quantity	2	<code>aMTMPM1_NUM_DIGITALS</code>	
<code>rail</code> Entity Quantity	2	<code>aMTMPM1_NUM_RAILS</code>	
Adjustable (<code>rail0</code>)	1		
V_{supply} pass-through (<code>rail1</code>)	1		
<code>store</code> Entity Quantity	2	<code>aBRAINSTEM_NUM_STORES</code>	
<code>system</code> Entity Quantity	1		
<code>timer</code> Entity Quantity	8	<code>aMTMBRAINSTEM_NUM_TIMERS</code>	

Table 5: MTM-PM-1 Hardware and Software Default Values⁷

⁷ Refer to `aMTMPM1.h` within the BrainStem Development Kit download for actual file.



Device Drivers

MTM-PM-1 devices do not require BrainStem drivers.

Capabilities and Interfaces

The MTM-PM-1 module software is built on Acroname's BrainStem technology. The module adheres to the BrainStem protocol on I²C and uses BrainStem software APIs. For the most part, functionality that is unique to the MTM-PM-1 is described in the following sections; refer to Table 6: Supported MTM-PM-1 BrainStem Entity API Methods for a complete list of all available API functionality. All shortened code snippets are loosely based on the C++ method calls – Python and Reflex are virtually the same. Please consult the BrainStem Reference for implementation details⁹.

System Entities

Every BrainStem module includes a single System Entity. The System Entity allows access to configuration settings such as the module address, input voltage, control over the user LED and many more.

Saving Entity Settings

Some entities can be configured and saved to non-volatile memory. This allows a user to modify the startup and operational behavior for the MTM-PM-1 away from the factory default settings. Saving system settings preserves the settings to become the new default. Most changes to system settings require a save and reboot before taking effect. Use the following command to save changes to system settings before reboot:

```
stem.system.save()
```

Saved Configurations	
Software Offset	I2C Rate
Router Address	I2C Pullup State
Heartbeat Rate	Boot Slot

Rail Entities

Rails on the MTM-PM-1 module are powerful (no pun intended); they allow other devices and peripherals to consume power from the MTM-PM-1 module in a precisely controlled fashion. Two (2) different rails are available for use: a software-adjustable voltage rail (`rail0`), and input voltage pass-through rail (`rail1`). These rails are accessed through an array of BrainStem rail class entities. The MTM-PM-1 module implements a subset of the

BrainStem rail class for each of these rails. Table 6: Supported MTM-PM-1 BrainStem Entity API Methods summarizes the implemented rail entity options for each entity index.

Both rails can be switched on or off through using the `setEnabledExternal` and `setDisableExternal` API. The current limit for each rail can be configured in software from 0A to 3A, although the behavior of each rail on an over-current event differs slightly:

- `rail0` will simply reduce the output voltage to drive the specified current.
- `rail1` will be turned off by the hardware if the output current goes above the set limit. The rail error must then be cleared before re-enabling the rail.

RAIL0 Voltage Setting

The output voltage is adjustable through the API across the operating range. Setting values outside the allowable range will return an error.

```
stem.rail[0].setVoltage(microvolts)
```

RAIL0 Operational Mode

`rail0` is unique as it contains an optional SMPS (switch mode power supply) pre-regulation stage power path. The pre-regulation power path stage can be configured through the API:

```
stem.rail[0].getOperationalMode(mode)
stem.rail[0].setOperationalMode(mode)
```

The mode parameter is an integer that correlates to the following:

- 0 (`operationalModeAuto`)
- 1 (`operationalModeLinear`)
- 3 (`operationalModeSwitcherLinear`)

Default operational mode is configured as `operationalModeLinear` which disables the SMPS pre-regulator.

For applications such as RF receiver sensitivity testing, it is suggested to operate only in linear regulation mode to eliminate potential EMI sources. When operating in linear mode, make sure to consider power dissipation through the linear regulation stage; a higher input voltage will result in higher power dissipation. When linear mode is desired as well as high current operation, it is recommended to run the input voltage close to the MTM-PM-1 module's minimum input voltage to reduce power regulation losses. Switch mode power supply operation will allow a broader range of input voltages while maintaining high current demand limits. Default behavior is to automatically change between



linear-mode and switcher-mode if an input voltage greater than 7.25V is applied with a 100mV hysteresis.

RAIL0 Operational State

`rail0` also features over-temperature and over-voltage protection. An over-temperature condition occurs when the board temperature crosses the safe operating threshold, and the rail is automatically disabled. The rail can then be re-enabled by first disabling and then re-enabling the rail via the software API. An over-voltage condition occurs when a voltage above the rail's set point is applied to the `rail0` output. When an over-voltage condition is detected, the hardware automatically disables the rail output. Once the over-voltage condition is removed, the rail output will resume desired operation without any software intervention.

```
stem.rail[0].getOperationalState(mode)
```

The value `mode` is an 8-byte value, defined as the following:

Mode	RAIL Operational Mode Description
0	Initializing (operationalState_Initializing)
1	Power Good (operationalState_PowerGood)
2	Power Fault (operationalState_PowerFault)
3	Linear Regulator Over-Temperature (operationalState_LDOverTemp)

RAIL0 Temperature

RAIL0's subsystem power stage temperature can be monitored at the adjustable rail (`rail0`) linear regulation stage. Reading this value is possible through the API.

```
stem.rail[0].getTemperature(temperature)
```

Temperature monitoring is also used internally to prevent the power regulation stage from over-heating and preserving the power stage. If an over-temperature condition occurs, the MTM-PM-1 module will disable the linear regulator until a safe operating temperatures is reached.

RAIL0 Kelvin Sensing

Remote sensing can be applied to compensate for line loss in a system often found in high transient load applications. The MTM-PM-1 provides a "3-wire" interface to provide feedback to the MTM-PM-1 power supply to adjust appropriately and dynamically.

```
stem.rail[0].getKelvinSensingMode(bEnable)
stem.rail[0].setKelvinSensingMode(bEnable)
```

The `bEnable` parameter is an integer that correlates to the following:

- 0 (kelvinSensingOff)
- 1 (kelvinSensingOn)

Determine whether kelvin sensing is enabled or disabled. Kelvin sensing can be disabled if the power stage incurs a fault on the `rail0` power stage.

```
stem.rail[0].getKelvinSensingState(state)
```

The `state` parameter is an integer that correlates to the following:

- 0 (kelvinSensingOff)
- 1 (kelvinSensingOn)

Digital Entities

The MTM-PM-1 has two (2) digital input/outputs (DIO) controlled by the digital entity. Each DIO is controllable via software and is independently current limited for both source and sink currents.

All DIO are input and output capable.

```
stem.digital[0].setConfiguration(mode)
stem.digital[0].getConfiguration(mode)
```

The `mode` parameter is an integer that correlates to the following:

- 0 (digitalConfigurationInput)
- 1 (digitalConfigurationOutput)
- 4 (digitalConfigurationHiZ)

If a digital pin is configured as an output mode, setting the digital logic level high

```
stem.digital[0].setState(mode)
stem.digital[0].getState(mode)
```

If a digital pin is configured in HighZ mode its internal circuitry has been disconnected to create a high impedance. There are no functions that can act on this configuration.

Digital	Input	Output	HighZ	RCServo
DIO0	Yes	Yes	Yes	None
DIO 1	Yes	Yes	Yes	None

I²C Entities

The MTM-PM-1 includes access to a single I²C bus, operating at a set 1Mbit/s rate.

NOTE: This bus, while user-accessible, is also used for primary BrainStem communication so there may be other,



non-user-initiated traffic as well, particularly with linked BrainStem units.

The maximum data size for individual `read` and `write` operations on this bus through the BrainStem API is 20 bytes. For example, sending 2 bytes (0xBEEF) through the I²C bus to a device with an address 0x42 would be written:

```
stem.i2c.write(0x42, 2, 0xBEEF)
```

Reading 2 bytes of data from a device with an address 0x42 would be written:

```
stem.i2c.read(0x42, 2, buffer)
```

Where `buffer` would be a char array in C++.

The I²C bus also includes, as a convenience, software-controllable 330Ω pull-up resistors on the SDA and SCL lines, disabled by default. When using the MTM-PM-1 in a linked system, only a single set of pull-ups should be enabled in order for the I²C bus to properly work (if more than one set is enabled, the lines cannot be pulled low for communication). Similarly, when using a single MTM device to communicate with an external device over the I²C

bus, either the internal pull-ups can be enabled, or external hardware pull-ups added.

```
stem.i2c.setPullUp(bEnable)
```

The `bEnable` parameter is an integer that correlates to the following:

- 0 (I²C pull-ups off)
- 1 (i2cSetPullup)

Temperature Entities

An optional thermocouple interface can be ordered installed from the factory. Standard orders do not include this interface.

K-Type Thermocouple

If the MTM-PM-1 was purchased with the thermocouple interface installed, one can use a K-type thermocouple. The input from a connected and compatible K-type thermocouple can be read using the following function:

```
stem.temperature.getTemperature(temp)
```

MTM-PM-1 Supported Entity Methods Summary

Detailed entity class descriptions can be found in the BrainStem Reference (<http://acroname.com/entities/index.html>). A summary of MTM-PM-1 class options are shown below. Note that when using Entity classes with a single index (aka, 0), the index parameter can be dropped. For example:

```
stem.system[0].setLED(1) → stem.system.setLED(1)
```

Entity Class	Entity Option	Variable(s) Notes
digital[0-1]	setConfiguration	
	getConfiguration	
	setState	
	getState	
i2c[0]	write	
	read	
	setPullup	Disabled by default. I2C communication requires a single set of pull-ups enabled across the bus
rail[0-1]	setEnabledExternal	
	getEnabledExternal	
	setCurrentLimit	
	getCurrent	
	getCurrentLimit	
	getVoltage	



rail[0]	setVoltage	
	setOperationalMode	
	getOperationalMode	
	getOperationalState	
	getTemperature	
	getKelvinSensingMode	
	setKelvinSensingMode	
	getKelvinSensingState	
	store[0-1]	getSlotState
loadSlot		
unloadSlot		
slotEnable		
slotDisable		
slotCapacity		
slotSize		
system[0]	save	
	reset	
	setLED	
	getLED	
	setSleep	
	setBootSlot	
	getBootSlot	
	getInputVoltage	
	getVersion	
	getModuleBaseAddress	
	getModuleSoftwareOffset	
	setModuleSoftwareOffset	
	setHBInterval	
	getHBInterval	
	getRouterAddressSetting	
	getModule	
	getSerialNumber	
	setRouter	
	getRouter	



	getModel	
temperature[0]	getTemperature	
timer[0-8]	getExpiration	
	setExpiration	
	getMode	
	setMode	

Table 6: Supported MTM-PM-1 BrainStem Entity API Methods⁸

⁸ See BrainStem software API reference at <https://acroname.com/reference/> for further details about all BrainStem API methods and information.



LED Indicators

The MTM-PM-1 board has a number of LED indicators to assist with MTM system development, debugging, and monitoring. These LEDs are shown in the diagrams below.

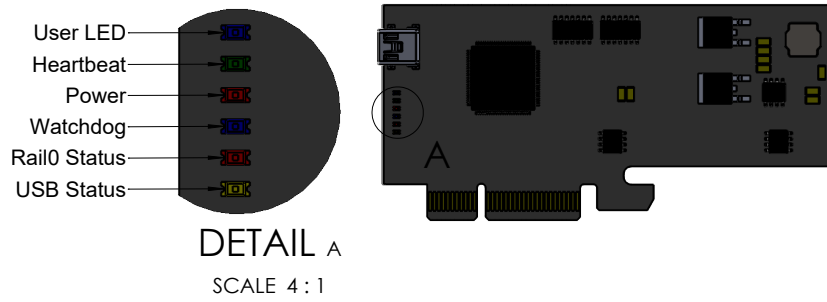

Figure 2: MTM-PM-1 LED Indicators



Edge Connector Interface

All MTM products are designed with an edge connector interface that requires a compatible edgeboard connector on the carrier PCB. Acroname recommends the through-hole PCI-Express (PCIe) Vertical Connector. The connectors can be combined with an optional retention clip, as shown below.

MTM Product	Manufacturer	Manufacturer Part Number	Description
MTM-Relay	Amphenol FCI Samtec	10018784-10203TLF PCIE-164-02-F-D-TH	PCI-Express 164-position vertical connector
MTM-IO-Serial	Amphenol FCI Samtec	10018784-10202TLF PCIE-098-02-F-D-TH	PCI-Express 98-position vertical connector
MTM-PM-1	Amphenol FCI Samtec	10018784-10201TLF PCIE-064-02-F-D-TH	PCI-Express 64-position vertical connector
MTM-USBStem	Amphenol FCI Samtec	10018784-10201TLF PCIE-064-02-F-D-TH	PCI-Express 64-position vertical connector
MTM-EtherStem	Amphenol FCI Samtec	10018784-10201TLF PCIE-064-02-F-D-TH	PCI-Express 64-position vertical connector
All Models	Amphenol FCI	10042618-003LF	PCI-Express Retention Clip (optional)

Table 7: PCI-Express Edge Connectors for MTM Products

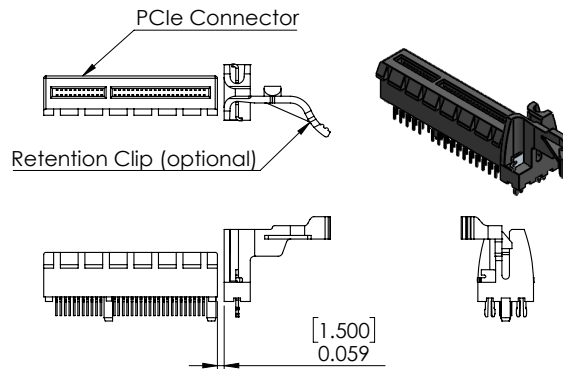

Figure 3: PCIe Vertical Connector with optional Retention Clip

MTM Edge Connector Specifications	Description
Contact Finish	Gold
Card Thickness	0.0625" [1.59mm]
Number of Rows	2
Number of Positions	Variable (see Table 7: PCI-Express Edge Connectors for MTM Products)
Pitch	0.039" (1.00mm)

Table 8: MTM Edge Connector Specifications

Amphenol FCI Drawings and Layout: <http://portal.fciconnect.com/Comergent/fci/drawing/10018784.pdf>
 Amphenol FCI Product Specification: <http://portal.fciconnect.com/res/en/pdf/files/Specs/gs-12-233.pdf>
 Samtec Product Catalog: http://suddendocs.samtec.com/catalog_english/pcie.pdf



Mechanical

Dimensions are shown in inches [mm]. 3D CAD models are available through the MTM-PM-1 product page's Downloads section.

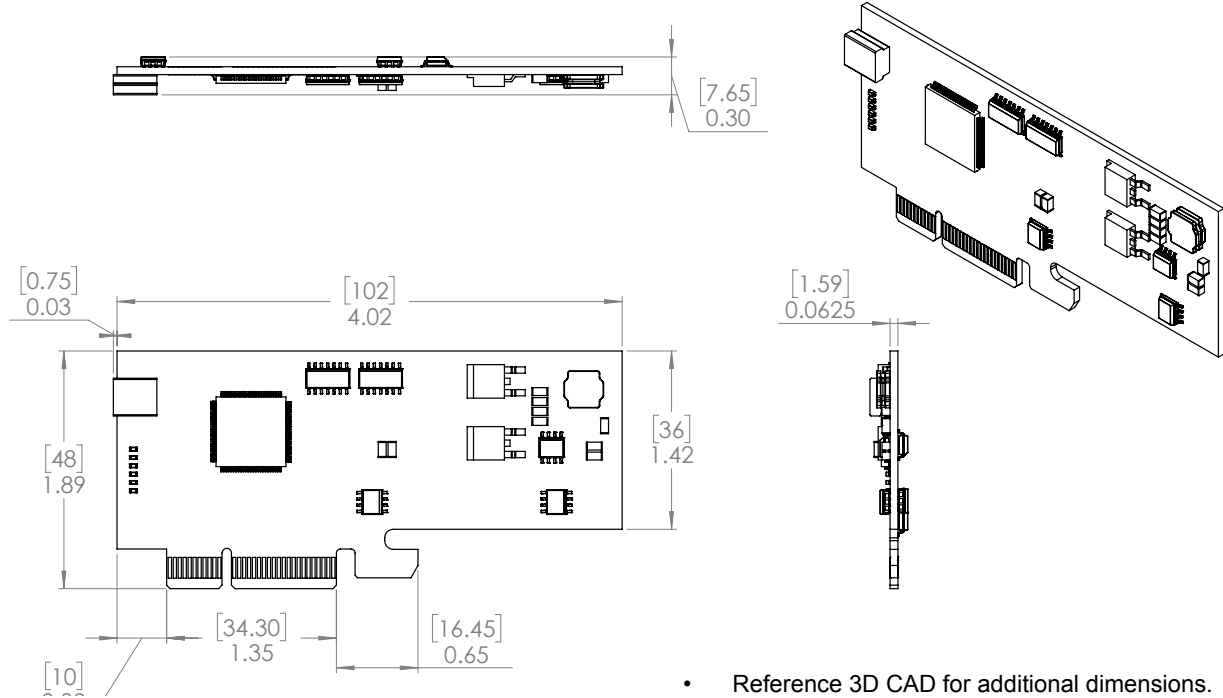

Figure 4: MTM-PM-1 Mechanical



Module Address Hardware Offset Configuration

A hardware offset is one of two ways to modify the devices Module/I2C address. For detailed information on BrainStem networking see the reference guide.

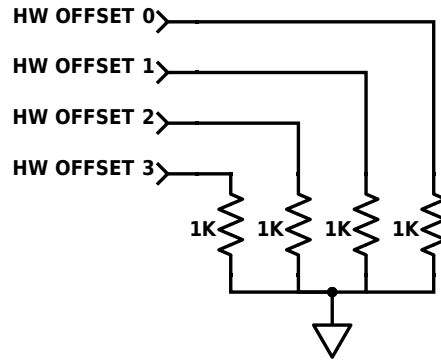

Figure 5: Module Address Hardware Offset



Document Revision History

All major documentation changes will be marked with a dated revision code

Revision	Date	Engineer	Description
1.0	September 29, 2015	JTD	Initial Revision
1.1	October 19, 2015	JTD	Reformatted, added Entity Section Specifics
1.2	October 23, 2015	MJK	Added pinout description
1.3	September 26, 2016	JTD	Updated information
1.31	October 12, 2016	LCD	Updated Overview, Features, Description, added DO jitter