



Long range LiDAR scanner designed specifically to provide UAVs with SLAM intelligence.

Critical navigation questions:

- Is there an obstacle ahead?
- How far away am I?
- Is a direction change safe?
- What is the best route?

Features:

- *Lightweight scanning LiDAR for sense-and-avoid applications*
- *Measures obstacles up to 100 m away*
- *Up to 4.5 complete data refreshes per second*
- *On-board analysis and navigation tools find escape routes*
- *Easy to configure and use, even by a low performance processor*
- *Interface via isolated alarms and serial port*
- *Simultaneous data collection and analysis for fast response to hazards*
- *Suitable for batteries ranging from 6.5 V to 30 V*
- *Continuously monitors internal system status to warn of low battery and other fault conditions.*



FM 654831

Table of contents

Product ordering codes	2
1. Overview of the SF40 LiDAR scanner	3
2. Specifications of the SF40	4
2. Quick start guide	5
3. SF40 hardware	6
3.1. Mounting the SF40 on an airframe	6
3.2. Power connector	6
3.3. User connector	7
3.4. LED indicators	7
3.5. The motor	8
3.6. The laser	8
3.7. Opto and servo	9
4. Communicating with the SF40	9
4.1. MMI communications	9
4.2. HMI communications	9
5. Navigation toolkit	10
5.1. Alarm zones	10
5.1.1. Alarm functions	10
5.2. Virtual laser range finder (VLRf)	11
5.3. SearchLight	11
5.4. Navigator	12
5.5. Mapper	12
6. Motor control subsystem	13
7. Instructions for safe use	13
7.1. Laser radiation information	13
8. Application examples	14
Appendix A :: MMI Commands	16
Appendix B :: Dimension drawings	19
Appendix C :: Main cable type 1, 35 cm	20
Appendix D :: Power cable assembly, 30 cm	20
Appendix E :: USB cable assembly, 1.8 m	21
Revision history	21

Table of figures

Figure 1 :: SF40 system overview	3
Figure 2 :: SF40 function overview	3
Figure 3 & 7 :: SF40 Controller PCB top: Power connections	5 & 6
Figure 4 & 8 :: SF40 Controller PCB top: USB user connections	5 & 7
Figure 5 :: LightWare Terminal showing menu options	5
Figure 6 :: SF40 mounting options	6
Figure 9 :: SF40 Controller PCB top: Serial user connections	7
Figure 10 :: SF40 Controller PCB top: LED indicators	7
Figure 11 :: SF40 Controller PCB bottom: Motor connections	8
Figure 12 :: SF40 Controller PCB bottom: Laser connections	8
Figure 13 :: SF40 Controller PCB bottom: Servo connections	9
Figure 14 :: Point cloud with Alarm zone	10
Figure 15 :: Point cloud with SearchLight	11
Figure 16 :: Point cloud with Navigator	12
Figure 17 :: Mapping function	12
Figure 18 :: Labelling on the SF40	13
Figure 19 :: Orientation of the SF40	14
Figure 20 :: Segment definitions	16
Figure 21 :: Dimension drawings of the SF40	19

Product ordering codes

Model family	Model name	Model description
SF40	SF40/C (100 m)	LiDAR scanner, max 100 m

Disclaimer

Information found in this document is used entirely at the reader's own risk and whilst every effort has been made to ensure its validity, neither LightWare Optoelectronics (Pty) Ltd nor its representatives make any warranties with respect to the accuracy of the information contained herein.

1. Overview of the SF40 LiDAR scanner

The SF40 is a smart sense-and-avoid LiDAR that detects obstacles near to autonomous vehicles and determines the safest route to travel past them.

Using a scanning laser to map the surrounding area and identify the presence and position of obstacles, built-in navigation tools locate gaps and spaces with sufficient clearance for safe navigation. On-board data analysis reduces the need for complicated processing by an external computer. Hardwired alarm outputs make it easy to interface the SF40 with conventional flight controllers and a serial port connection allows for greater interaction when navigation becomes more complex.

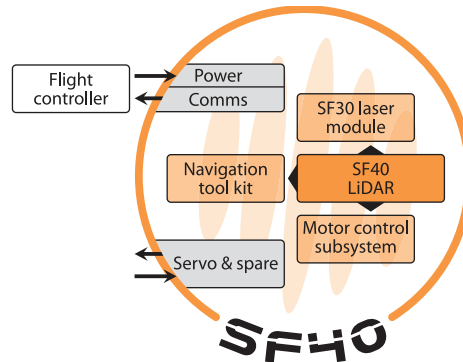

Figure 1 :: SF40 system overview

The SF40 uses a scanning laser rangefinder to measure on a 360 degree disc with a radius of 100 meters. Collected data is stored in memory and continually refreshed as the laser scans around. The speed of rotation can be set to 1, 2.25 or 4.5 revolutions per second corresponding to measuring resolutions of 0.03, 0.06 and 0.12 meters respectively. Time critical functions are managed by an FPGA leaving the 32-bit Arm Cortex-M3 processor to handle the data analysis and monitor system performance and reliability.

Note

The SF40 is designed to collect and analyze data internally. Whilst this data can be downloaded to an external controller, the SF40 is not intended to provide a continuous data stream. Attempting to download data continuously will result in a significantly reduced update rate.

Data analysis takes place asynchronously from the data collection so that numerous independent calculations can be carried out very quickly. An analytical tool kit provides the framework for making navigation decisions. Some of the tools run autonomously, such as alarm conditions that are evaluated continuously without the need for intervention by the flight controller. Other tools answer high level navigational questions such as "Is it safe for me to change direction?" or "Which way should I go now?" Tools can be used sequentially and in combination with status information to form sophisticated strategies that can handle numerous mission requirements.

The principle navigation tools are:

- | | |
|--|--|
| <ul style="list-style-type: none"> Alarm zones Virtual Laser Range Finder (VLRf) SearchLight Navigator Mapper | <ul style="list-style-type: none"> - autonomously monitors preselected areas to warn of any obstacles - measures the distance to a target in any direction - checks that an area is clear of obstacles before a direction change is made - finds open pathways between obstacles - provides all the distance measurements in a specified region |
|--|--|

SF40 LiDAR functions	
System tools	Navigation tools
Energy controls	Alarm zones
Status register	Virtual Laser
External inputs	Range Finder
Laser controls	SearchLight
Motor controls	Navigator
Servo controls	Mapper
	Alarm register

Figure 2 :: SF40 functions overview

2. Specifications of the SF40

	SF40/C (100 m)
Range	0 ... 100 meters (natural targets)
Revolutions per second	4.5 / 2.25 / 1 (Measuring mode is selectable)
Resolution	0.12 / 0.06 / 0.03 meters (based on rev/sec)
Readings per revolution	2022 / 2022 / 1654 (based on rev/sec)
Readings per second	9158 / 4578 / 1654 (based on rev/sec)
Main power supply voltage	6.5 ... 30.0 V DC
Main power supply current	1 A (max)
User power supply voltage	2.7 V ... 5.5 V DC
Outputs & interfaces	Serial, two hardwired alarms, servo connections & spare
Dimensions	91 mm (height) x 79 mm (largest diameter)
Weight	270 g (excluding cables)
Laser power	20 W (peak), 11 mW (average), Class 1M
Optical aperture	51 mm
Beam divergence	0.2°
Operating temp.	0 ... 40° C
Approvals	FDA: 1630995-000 (2016/09)

2. Quick start guide

1. CAUTION - The SF40 LiDAR contains a laser and should never be aimed at a person or an animal. Do not look at the beam directly with optical instruments.
2. Download *LightWare Terminal* software from www.lightware.co.za > Library > Documents > Software onto your PC. Open the installer package and follow the installation instructions. Everything needed for communicating with SF40 will automatically be installed.
3. Mount the SF40 onto the autonomous vehicle with the orientation label facing forwards.
4. Plug the “SF40 power cable” into the Power connector, and the open wires to a power supply or battery of between 6.5 V and 30 V with a current capacity of 1 A.

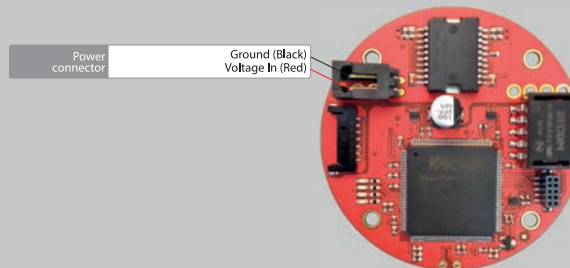

Figure 3 :: SF40 Controller PCB top: Power connections

5. To provide serial communication to the SF40, attach the open wires of the “SF40 USB adaptor cable” supplied to the User connector.

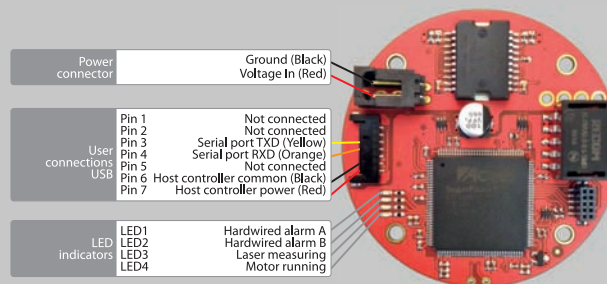

Figure 4 :: SF40 Controller PCB top: User connections

6. Plug the other end of the “SF40 USB adaptor cable” into a PC.
7. Open *LightWare Terminal* software on the PC, a connection with the SF40 will automatically be established using baud rate of 115200,8,n,1.
8. Turn on the power supply.
9. The motor will start to turn and indicator LED3 “Laser measuring” and LED4 “Motor running” will light up.
10. In the *LightWare Terminal* window type “?EB<CR><LF>” and the current battery voltage will display.
11. Press the <ESC> key to display the user menu in Human-Machine-Interface (HMI) mode, as displayed below:

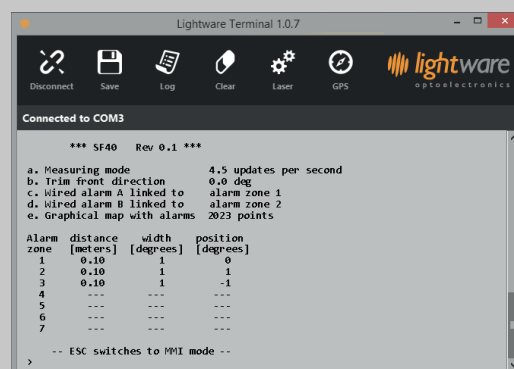

Figure 5 :: LightWare Terminal showing menu options

12. Press the appropriate key to select a menu item, e.g. type <A> for “a. Measuring mode” to select an operating speed.
13. Press <ESC> to return to Machine-Machine-Interface (MMI) mode.
14. Press “?A” to display the alarm register.
15. Confirm all pre-flight settings and disconnect the SF40 from the PC.

3. SF40 hardware

3.1. Mounting the SF40 on an airframe

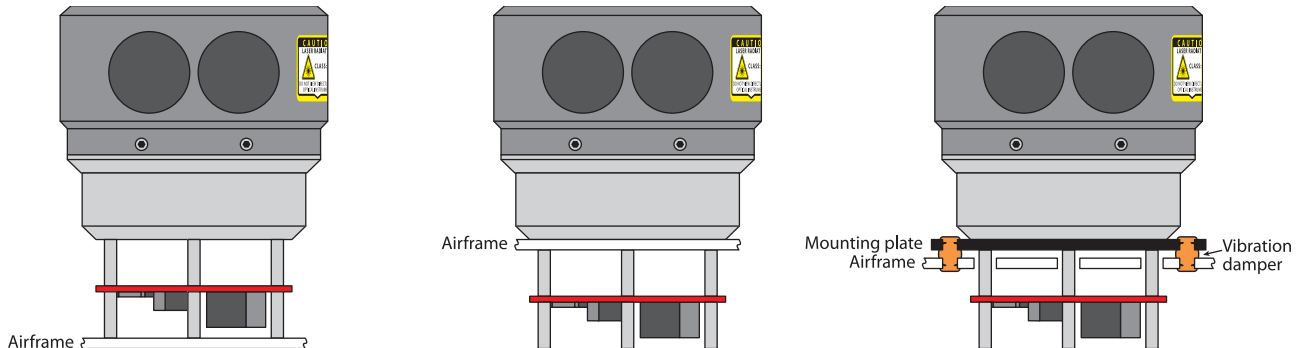

Figure 6 :: SF40 mounting options

3.2. Power connector

The power supply for the board is from 6.5 V to 30.0 V DC, connected to Pins 1 and 2 of the Power connector.

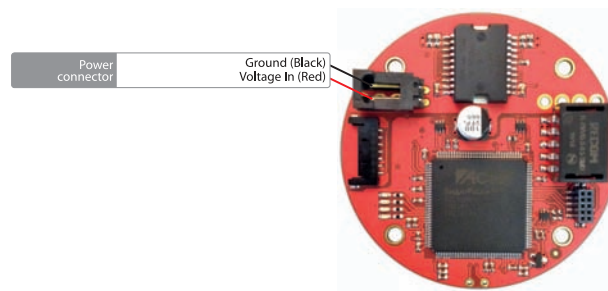

Figure 7 :: SF40 Controller PCB top: Power connections

- The power supply current capacity should be at least 1 A
- The typical power consumption with the motor running is 4.5 W
- The current drawn reduces at higher supply voltage to keep an approximately constant power consumption
- The battery voltage reading can be trimmed to compensate for voltage losses down the wires
- There is a low battery system status flag that becomes active when the battery voltage drops below a preset level. This can be read through the serial port or linked to the hardwired alarms
- There is a flat battery system status flag that becomes active when the battery is too flat to drive the motor. This can be read through the serial port or linked to the hardwired alarms
- The motor is turned off when the battery is flat to reduce the current consumption
- The flat battery status flag of the internal status register remains active until it is reset by reading the status register or restarting the motor.

3.3. User connector

Serial communication, both in HMI and MMI modes, is accessed via the electrically isolated, User connections 7 way header. The power for the user connector accommodates voltage supply in the range of 2.7 V ... 5.5 V DC and should be connected to pins 6 and 7 of the User connector.

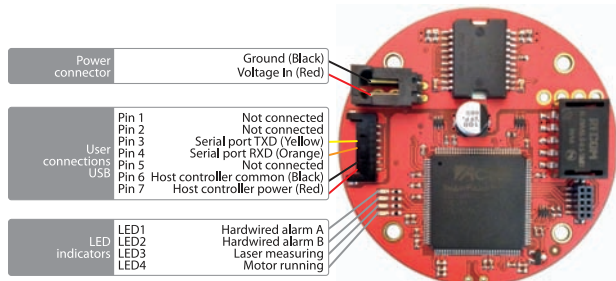

Figure 8 :: SF40 Controller PCB top: USB user connections

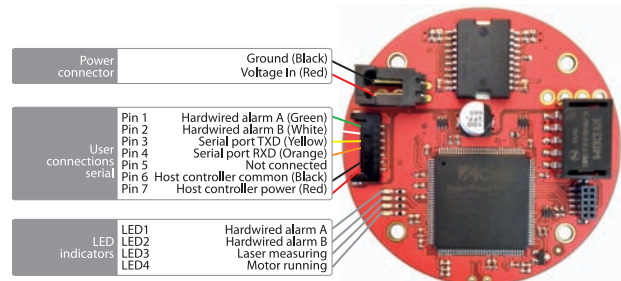

Figure 9 :: SF40 Controller PCB top: Serial user connections

The user connections are via a serial port (logic level) and two hardwired alarm outputs:

- User connections and hardwired alarms are electrically isolated from the rest of the board with an isolation capability of 1000 V DC
- Power for the user interface comes from the user side and can be from 2.7 V to 5.5 V DC
- The hardwired alarm outputs can be linked to any alarm zone or internal status flag as required.

3.4. LED indicators

The SF40 controller PCB has four LED's to indicate alarms, laser operation and the motor's status.

- LED1 Hardwired alarm A This alarm can be linked to any alarm zone or the system status flags as required
- LED2 Hardwired alarm B This alarm can be linked to any alarm zone or the system status flags as required
- LED3 The laser is measuring This LED comes on when the measurement data from the laser is valid
- LED4 The motor is running This LED comes on when the motor is running at constant speed.

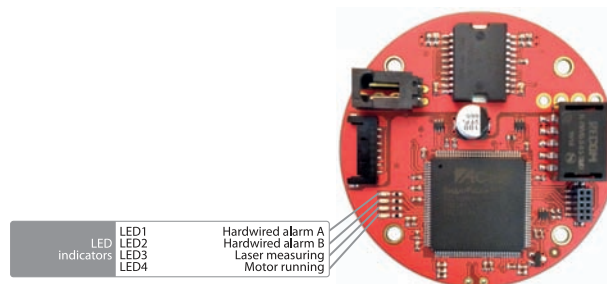

Figure 10 :: SF40 Controller PCB top: LED indicators

3.5. The motor

The SF40 Controller PCB controls a 3 phase, brushless, DC motor and has the following characteristics:

- The motor speed can be set to stopped, 1, 2.25 or to 4.5 revolutions per second
- The motor direction can be set to clockwise or counter-clockwise to support inverted operation
- The motor runs at constant power and torque at all speeds and power supply voltages
- The motor is switched into economy mode to save power once it is running at the set speed
- The motor speed, direction, torque and economy settings can be changed on the fly
- The motor position is monitored by an onboard opto-coupler.

The Motor connections are on the SF40 controller PCB on a 4 way header.

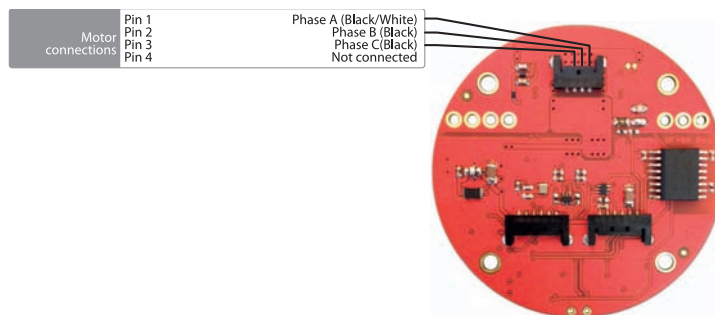

Figure 11 :: SF40 Controller PCB bottom: Motor connections

3.6. The laser

There are interfaces to an SF30 laser range finder that is inside the cap of the SF40. The Laser connects to the SF40 controller PCB through slip-rings and onto a 6 way header.

- Synchronization and distance data signals come from the SF30
- The SF40 configures the SF30 laser to give the optimum angular and range resolution for the motor speed selected.

There is a spare digital input pin with a 10k pull-up resistor to 3.3 V on pin 6 of the Laser header:

- This input is 5 V tolerant
- The status of the input can be read through the serial port or linked to a hardwired alarm.

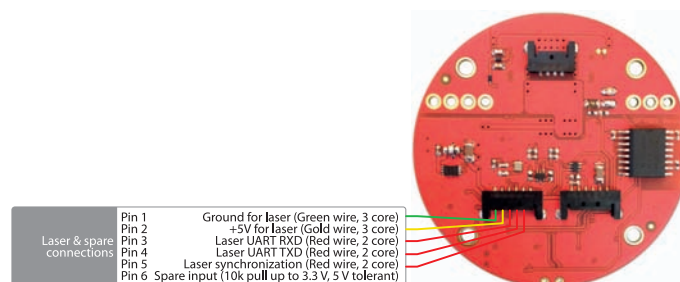

Figure 12 :: SF40 Controller PCB bottom: Laser connections

3.7. Opto and servo

A Servo output is available on the SF40 controller PCB on a 6 way header. The servo driver is suitable for small digital or analog servos running from +5 V DC:

- The end points of the servo can be adjusted to give an exact range of travel
- The servo position can be controlled through the serial port.

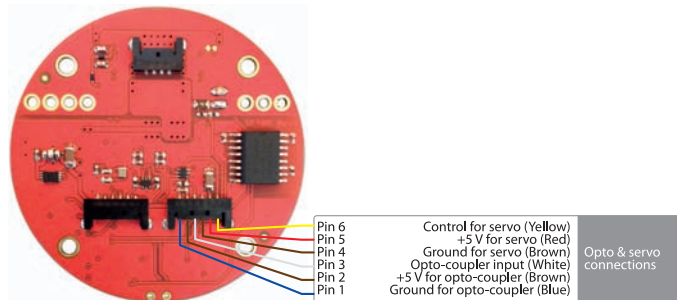

Figure 13 :: SF40 Controller PCB bottom: Servo connections

4. Communicating with the SF40

The SF40 has two modes of serial port communication:

- Machine-machine-interface mode (MMI): for communication with a microprocessor using ASCII mnemonics and command strings to change settings
- Human-machine-interface mode (HMI): for human interaction using menus for selecting and entering new settings.

4.1. MMI communications

At initial power up, the SF40 is in MMI mode. With the “SF40 USB adaptor cable” connected to the appropriate User connection pins, and to a PC, open *LightWare Terminal* software. Establish a connection with the SF40 using 115200 baud with no handshaking (115200,8,N). Note the communication conventions below:

- Mnemonics are used to send commands and request data
- Settings can be changed using the # command and read back using the ? command
- Commands are echoed back to the host controller to verify that they have been received
- The <CR><LF> symbols (the enter key) are sent once a command is completed
- Settings identifiers issued as part of a command can be in lower or upper case
- Angles entered can use positive or negative notation so that 270 degrees is equivalent to -90 degrees
- There must be no spaces in a command
- There is a limited amount of time that the host controller has to output a command once it has started
- If it takes longer then the command is ignored
- The time limit can be set
- Press the <ESC> key to switch to HMI communication mode.

If an alternative baud rate is required, select a baud rate through the User menu, power the SF40 off and on again, and re-establish connection with *LightWare Terminal* software using the new baud rate.

See “Appendix A :: MMI Commands” for a full list of the SF40’s available commands.

4.2. HMI communications

At initial power up, the SF40 is in MMI mode. With the “SF40 USB adaptor cable” connected to the appropriate User connection pins, and to a PC, open *LightWare Terminal* software. Establish a connection with the SF40 using 115200 baud with no handshaking (115200,8,N). Change to HMI mode by pressing the <ESC> key and the SF40’s software menus will display in the *LightWare Terminal* window. Note the communication conventions below:

- Communications are in ASCII format and menus are used to change settings
- Navigate between the menus using the arrow keys
- Data can be entered at the cursor by selecting the menu option, or by typing in direct MMI commands without a timeout
- Pressing the <ESC> key to switch back to MMI mode.

If an alternative baud rate is required, select a baud rate through the User menu, power the SF40 off and on again, and re-establish connection with LightWare Terminal software using the new baud rate.

See “Appendix A :: MMI Commands” for a full list of the SF40’s available commands.

5. Navigation toolkit

The navigation toolkit consists of five features designed to sense potential threats to UAV safety and to avoid these obstacles. Firstly, “Alarm zones” allow for the configuration of risk areas to alert of obstacle proximity. Secondly, the “Virtual laser range finder” reads the distance in given direction to allow the UAV to hold a specified station. “SearchLight” can check that a flight corridor is clear before the UAV changes direction. The “Navigator” tool examines a specified region and finds the direction of the clearest pathway. Lastly, the “Mapper” function provides two dimensional maps of a specified region.

5.1. Alarm zones

Seven configurable alarms zones can be set within the measuring plane to alert obstacle proximity. Each zone can be set with an individualized alarm distance, angular width and aiming direction. Typically, one zone would cover 360 degrees around the vehicle at close range to alert when people get too close to the moving parts. Additionally, a forward looking alarm zone is used to detect obstacles in the direction of motion. Other alarm zones can check that specific directions are clear of obstructions before course changes are made.

The status of the alarms can be read from the serial port and any two alarms can be linked to the hardwired outputs. The alarm zone definitions are stored in non-volatile memory making them available immediately when power is applied. Once the SF40 is running the alarms are updated continuously without the need for any external commands.

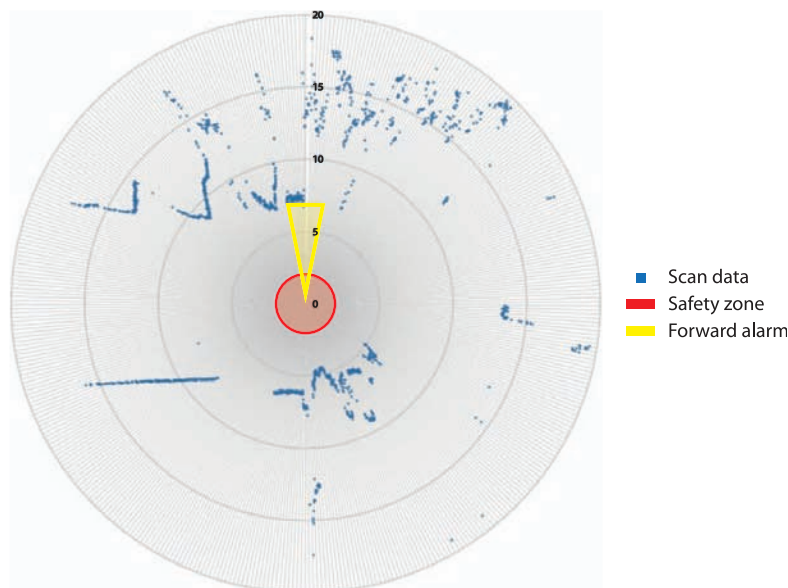

Figure 14 :: Point cloud with Alarm zone

5.1.1. Alarm functions

- Alarm zones are created by entering the distance, angular width and direction
- The alarm zones are automatically saved in non-volatile memory and are active immediately after power up
- There are two hardwired alarm outputs and 8 register alarms available through the serial port
- The hardwired alarm outputs can be linked to any of the register alarms
- The alarms register can be accessed from the serial port using the command: ?A
- The structure of the alarms register is:

bit 0	=	Alarm 1	Goes high when the corresponding alarm is active
bit 1	=	Alarm 2	Goes high when the corresponding alarm is active
bit 2	=	Alarm 3	Goes high when the corresponding alarm is active
bit 3	=	Alarm 4	Goes high when the corresponding alarm is active
bit 4	=	Alarm 5	Goes high when the corresponding alarm is active
bit 5	=	Alarm 6	Goes high when the corresponding alarm is active
bit 6	=	Alarm 7	Goes high when the corresponding alarm is active
bit 7	=	Global alarm	Goes high when any alarm is active

5.2. Virtual laser range finder (VLRf)

The virtual laser range finder (VLRf) tool is used to find the distance in any direction on the measuring plane. VLRf can assist with keeping station at a fixed distance from a target or measuring how far away an obstacle is. Any number of VLRfs can be created that aim in different directions. This allows for accurate position holding within a confined space and provides confirmation of GPS location using adjacent buildings or other known structures as reference points.

5.3. SearchLight

The SearchLight tool answers two navigation questions. The first is, “Can I safely change to a new direction?” The second is, “Where is the closest obstacle in that direction?”

SearchLight checks that a corridor is clear before the vehicle changes direction. It can be aimed in any direction on the measuring plane and the beam divergence adjusted to cover the width of the corridor of interest. SearchLight finds the closest obstacle within the corridor and reports its distance and angle from the present flight path.

SearchLight is used to confirm that direction changes are safe before they are made rather than waiting for the alarms after the direction change has been made. Several SearchLights can be used together to triangulate the vehicle’s position between fixed objects and wide beam SearchLights can be used to check for clearance in different quadrants.

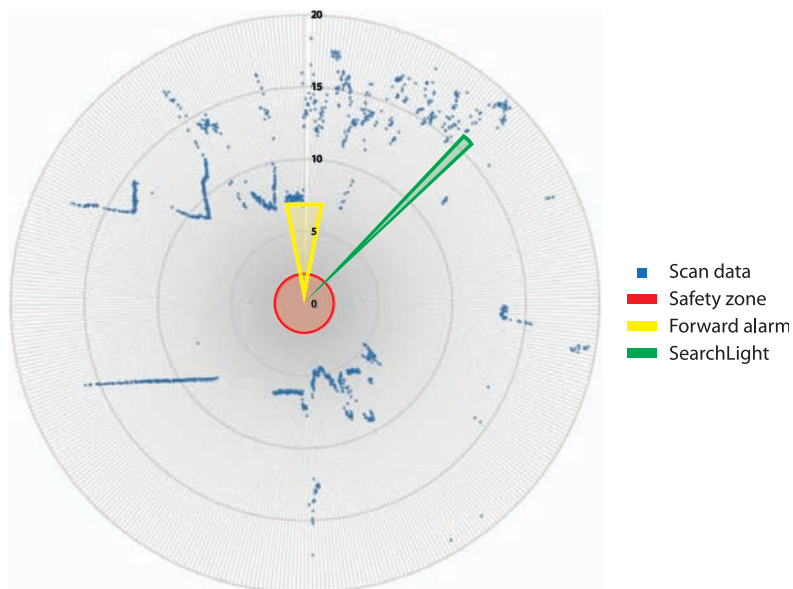

Figure 15 :: Point cloud with SearchLight



5.4. Navigator

The Navigator tool answers the question “Which way can I go now?”. It examines a specified region and finds the direction of the clearest pathway. The results can be used to direct the vehicle into open space and away from obstacles.

Navigator can be run at any time or activated when a forward looking alarm zone detects an approaching obstacle. The flight controller can configure Navigator with a directional bias so that the recommended escape route is away from known hazards. This can be useful during search and rescue missions when flying close to a cliff face and a bias away from the cliff face would be the safer option.

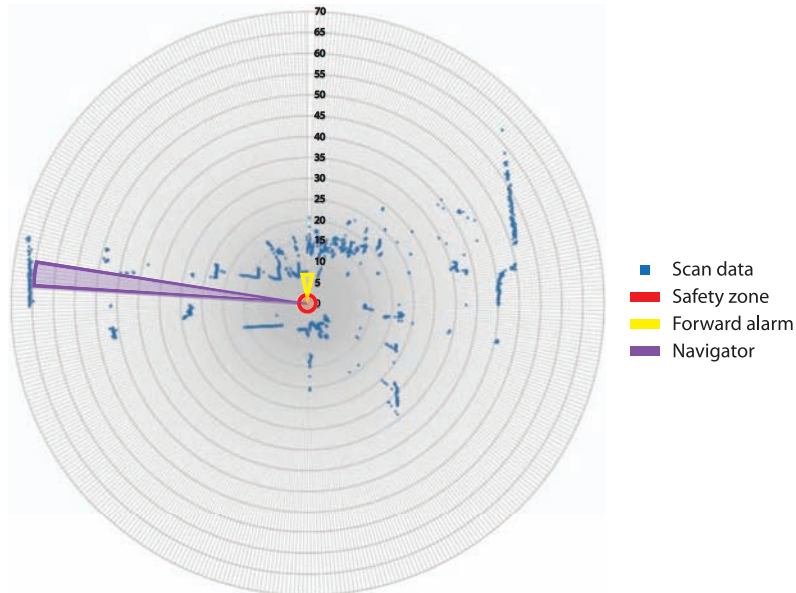

Figure 16 :: Point cloud with Navigator

5.5. Mapper

The Mapping function provides detailed two dimensional maps of a specified region. These maps can be analyzed by the host controller so that additional measurements or navigation decisions can be made.

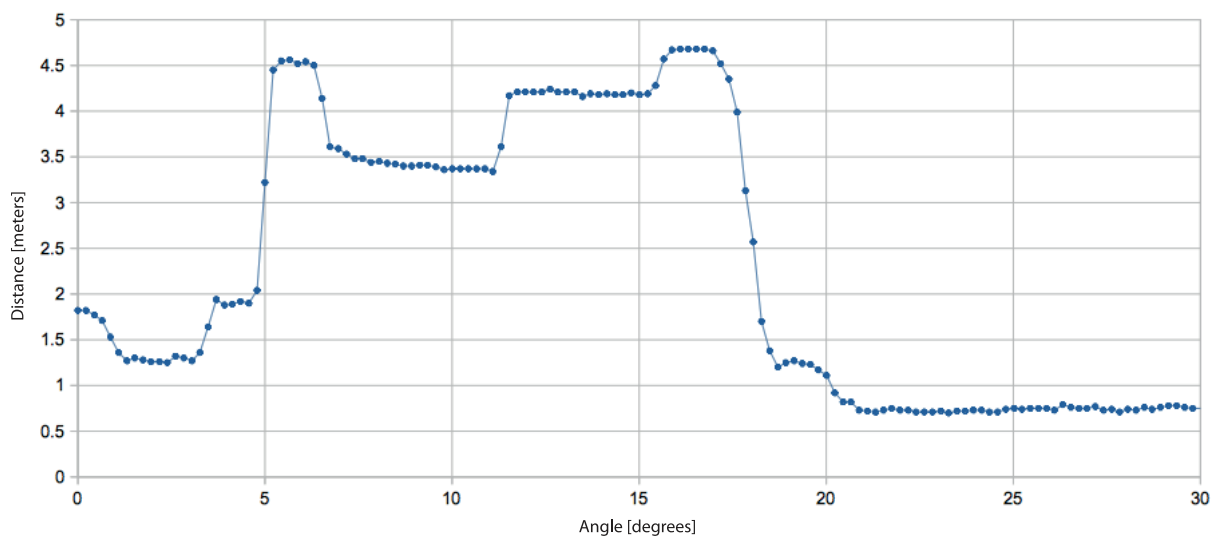

Figure 17 :: Mapping function

6. Motor control subsystem

In addition to collecting and analyzing data from the scanning laser, the SF40 continuously monitors the status of internal systems and the status register can be read by the host controller. System status checks include monitoring the battery voltage, the smooth running of the motor and the correct functioning of the laser. Status flags can be linked to the hardwired alarms to provide a warning of critical system faults, such as the battery running low.

There is provision to control an external servo motor that can be used to position the SF40 or for any other purposes. The end points of the servo can be trimmed to allow for precise positioning using commands sent through the serial port.

A spare digital input on the Laser 6 way header is continuously monitored and its state is reflected in the system status register. This input can be linked to a hardwired alarm and read using the serial port.

The SF40 includes a high performance motor controller and efficient power supplies that allows it to run from different battery types and voltages ranging from 6.5 V DC up to 30 V DC. The power consumption during normal running is constant at 4.5 Watts.

7. Instructions for safe use

The SF40 is a laser rangefinder that emits ionizing laser radiation. The level of the laser emission is Class 1M which indicates that the laser beam is safe to look at with the unaided eye but must not be viewed using binoculars or other optical devices at a distance of less than 15 meters. Notwithstanding the safety rating, avoid looking into the beam and switch the unit off when working in the area.

CAUTION -- The use of optical instruments with this product will increase eye hazard.

The SF40 should not be disassembled or modified in any way. The laser eye safety rating depends on the mechanical integrity of the optics and electronics so if these are damaged do not continue using the SF40. There are no user serviceable parts and maintenance or repair must only be carried out by the manufacturer or a qualified service agent.

No regular maintenance is required for the SF40 but if the lenses start to collect dust then they may be wiped with suitable lens cleaning materials. Make sure that the SF40 is switched OFF before looking into the lenses.

The SF40 should be mounted using the four holes provided in the circuit board. Do not hold or clamp the lens tubes as this may cause damage and adversely affect the laser safety rating.

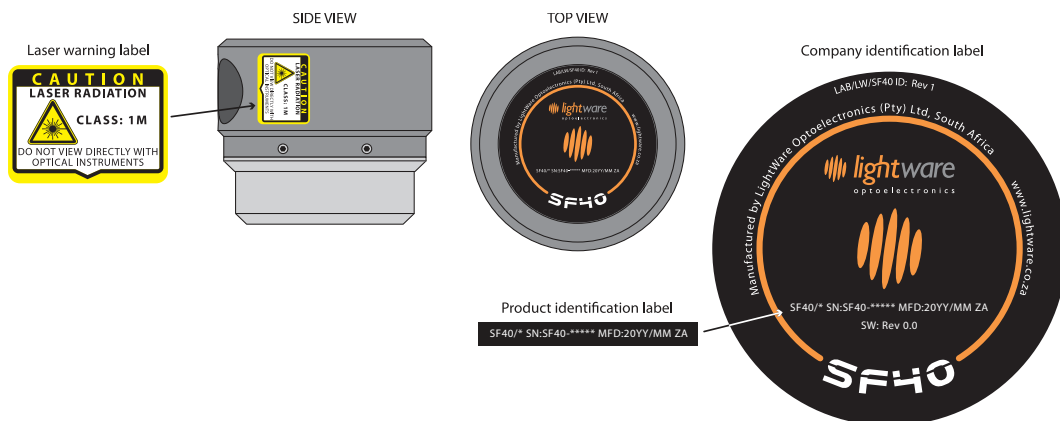

Figure 18 :: Labelling on the SF40

7.1. Laser radiation information

Specification	Value / AEL	Notes
Eye safety classification	Class 1M	
Laser wavelength	905 nm	
Pulse width	< 20 ns	
Pulse frequency	< 36 kHz	
Peak power	< 10 W	50 millimeter aperture at 2 meters
Average power	< 0.6 mW	7 millimeter aperture
Average energy per pulse	< 300 nj	
NOHD	15 m	Distance beyond which binoculars with may be used safely

8. Application examples

7.1. Using the MMI to set alarm zone 1 with a range of 10 meters, an angular width of 5 degrees and pointing directly forwards:

#AD1,10.0<CR><LF>	set the range to 10 meters
#AW1,5<CR><LF>	set the angular width to 5 degrees
#AA1,0<CR><LF>	set the aiming direction to 0 degrees (forwards)
?A<CR><LF>	check the alarm register for obstacles
<space>0x00<CR><LF>	the alarm register is returned as a hexadecimal number

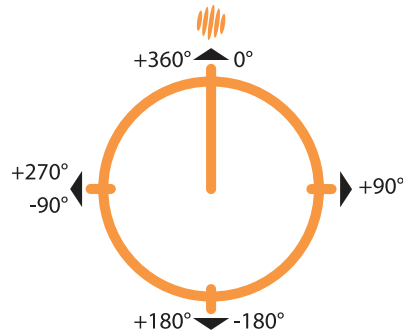

Figure 19 :: Orientation of the SF40

7.2. Using the MMI to set alarm zone 2 with a range of 2m and covering 360 degrees around the AUV:

#AD2,2<CR><LF>	set the range to 2 meters
#AW2,360<CR><LF>	set the angular width to 360 degrees
#AA2,0<CR><LF>	set the aiming direction to 0 degrees (forwards)
?A<CR><LF>	check the alarm register for obstacles
<space>0x00<CR><LF>	the alarm register is returned as a hexadecimal number

7.3. Linking the hardwired alarms A and B to alarm zones 1 and 2:

#OL1,0<CR><LF>	link hardwired alarm A to alarm zone 1
#OL2,1<CR><LF>	link hardwired alarm B to alarm zone 2

7.4. Setting up the low battery alarms to compensate for 0.5 volt drop down the wires, a low battery warning at 12.0 volts and a flat battery alarm at 11.0 volts:

?EB<CR><LF>	read the battery voltage before correcting for the wire losses
<space>13.5<CR><LF>	the battery voltage is returned
#EBT,0.5<CR><LF>	compensate for a 0.5 volt loss through the wires
?EB<CR><LF>	read the battery voltage after correcting for the wire losses
<space>13.0<CR><LF>	the corrected battery voltage is returned
#EBL,12.0<CR><LF>	set the low voltage alarm to 12.0 volts
#EBF,11.0<CR><LF>	set the flat battery alarm to 11.0 volts

7.5. Measuring how far it is to a wall located directly ahead:

?LD<CR><LF>	this is an abbreviated command to measure in the forward direction
<space>27.56<CR><LF>	the distance to the wall is returned

7.6. Adjusting the front direction 45 degrees to the right to compensate for the mounting arrangement:

?MBF<CR><LF>	check the current direction of the front
<space>0.0<CR><LF>	the present front direction is in line with the default factory setting
#MBF,45.0<CR><LF>	change to the new front position
?MBF<CR><LF>	confirm the new front direction
<space>45.0<CR><LF>	the new front direction is 45.0 degrees to the right of the default position

7.7. Check for an alarm condition then check that there is a clear corridor -45 degrees from the front direction and 5 degrees wide:

?A<CR><LF>	check the alarm register for obstacles
<space>0x81<CR><LF>	alarm zone 1 is active so prepare to take evasive action
?TS,5,-45<CR><LF>	aim a searchlight in the direction to be checked
<space>313.0,17.56<CR><LF>	there is clear corridor centred on -47 degrees that is 17.56 meters long

7.8. Find the best escape route in the front, right quadrant that is at least 3 degrees wide:

```
?TN,90,45,3<CR><LF>      create a search zone 90 degrees wide centred on 45 degrees
<space> 37.0,54.78<CR><LF> there is a clear corridor 54.78 meters long available at 37.0 degrees to the right of the
front direction
```



Appendix A :: MMI Commands

A.1. Commands to change settings have the following format:

#ABCnnn<CR><LF>

#	indicates that a value is to be entered
ABC	identifies which value is to be changed
nnn	numeric values to be entered
<CR><LF>	indicates the end of the command transmission or the <enter> key

A.2. Commands are acknowledged by the SF40 with <CR><LF> once the command has been executed.

A.3. Values can be read back using the ? symbol with the following format:

?ABCnn

?	indicates that a value is to be read
ABC	identifies which value is to be read
nn	are optional numeric parameters

A.4. Values returned using the ? command are formatted as follows:

<space>nnn,nnn<CR><LF>

<space>	precedes the numerical value returned
nnn	is the value requested
,	a comma is used to delimit values when multiple results are returned
<CR><LF>	indicates that all results have been returned

A.5. Different numeric types are assigned the following symbols:

aaa	a direction or aiming angle in degrees
ddd	a distance value in meters
nnn	a number with no dimensions
www	an angular width in degrees

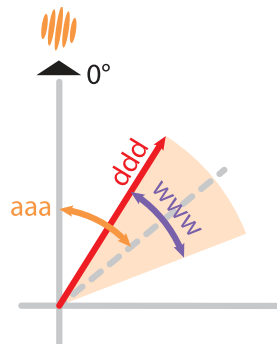

Figure 20 :: Segment definitions

NOTE: units of measurement must not be included in the commands

A.6. Different number formats are identified as follows:

nnn	numeric values that are whole numbers only
nn.n	numeric values with decimal places
0xhh	8 bit hexadecimal value
0xhhhh	16 bit hexadecimal value

Top level	Top symbol	Second level	Second symbol	Third level	Third symbol	Command structure	Returns	Values	Range	Units	Meaning					
Alarms	A					?<CR><LF>	<space>abcdef<CR><LF>	abcdef	ASCII	text	Product description.					
						?A<CR><LF>	<space>0xhh<CR><LF>	0xhh	0x00 ... 0xff		Returns the alarm register.					
								bit 0	alarm zone 1	0 => no alarm	1 => alarm is on					
								bit 1	alarm zone 2	0 => no alarm	1 => alarm is on					
								bit 2	alarm zone 3	0 => no alarm	1 => alarm is on					
								bit 3	alarm zone 4	0 => no alarm	1 => alarm is on					
								bit 4	alarm zone 5	0 => no alarm	1 => alarm is on					
								bit 5	alarm zone 6	0 => no alarm	1 => alarm is on					
								bit 6	alarm zone 7	0 => no alarm	1 => alarm is on					
								bit 7	all alarm zones	0 => no alarms	1 => one or more alarms are on					
						Alarm distance	D			#AD,dd.dd<CR><LF>	<CR><LF>	N	1 ... 7			Sets the distance below which the first alarm will activate.
									Alarm number	N	?ADN<CR><LF>	<space>dd.dd<CR><LF>	dd.dd	0.00 ... 100.0	meters	Returns the distance setting of the first alarm zone.
						Alarm width	W			#AW,www<CR><LF>	<CR><LF>	N	1 ... 7			Sets the angular width of the first alarm zone.
									Alarm number	N	?AWN,www<CR><LF>	<space>www<CR><LF>	www	0 ... 360	degrees	Returns the angular width of the first alarm zone.
Alarm aiming direction	A			#AA,aaa<CR><LF>	<CR><LF>	N	1 ... 7			Sets the aiming direction of the first alarm zone.						
			Alarm number	N	?AAN,aaa<CR><LF>	<space>aaa<CR><LF>	aaa	0 ... 360	degrees	Returns the aiming direction of the first alarm zone.						
					?AAN<CR><LF>	<space>aaa<CR><LF>	aaa	0 ... 360	degrees	Sets the aiming direction of a specific alarm zone. This direction is defined at the center of the alarm zone.						

Top level	Top symbol	Second level	Second symbol	Third level	Third symbol	Command structure	Returns	Values	Range	Units	Meaning
Energy	E	Battery	B			?E<CR><LF>	<space>0xhhhh<CR><LF>	0xhhhh	0x0000 ... 0xffff		Returns the system status register.
						?EBT,n.n<CR><LF>	<CR><LF>				Reads the battery voltage after correcting for wire losses.
						?EBT<CR><LF>	<space>n.n<CR><LF>	n.n	-1.0 ... +1.0	volts	Trims the battery voltage reading to compensate for losses down the wires.
						#EBL,nn.n<CR><LF>	<CR><LF>				Sets the low battery alarm voltage level.
						?EBL<CR><LF>	<space>nn.n<CR><LF>	nn.n	6.0 ... 30.0	volts	
						#EBF,nn.n<CR><LF>	<CR><LF>				Sets the flat battery alarm voltage level.
						?EBF<CR><LF>	<space>nn.n<CR><LF>	nn.n	6.0 ... 30.0	volts	
						#EM,nn<CR><LF>	<CR><LF>				Sets how much power saving should be applied once the BLDC motor has reached constant speed. Setting this to 0% disables this power saving function.
						?EM<CR><LF>	<space>nn<CR><LF>	nn	0 ... 50	%	
						Motor power saving	M				

Top level	Top symbol	Second level	Second symbol	Third level	Third symbol	Command structure	Returns	Values	Range	Units	Meaning
Filters	F					?F<CR><LF>	<space>0xhhhh<CR><LF>	0xhhhh	0x0000 ... 0xffff		Returns the system status register.

Top level	Top symbol	Second level	Second symbol	Third level	Third symbol	Command structure	Returns	Values	Range	Units	Meaning
Global registers	G	Status register	S			?G<CR><LF>	<space>0xhhhh<CR><LF>	0xhhhh	0x0000 ... 0xffff		Returns the system status register.
						?GS<CR><LF>	<space>0xhhhh<CR><LF>	0xhhhh	0x0000 ... 0xffff		Returns the system status register.
								bit 0	motor stopped	0 => motor running	1 => motor stopped
								bit 1	motor direction	0 => clockwise	1 => anti-clockwise
								bit 2	motor fault	0 => no motor fault	1 => motor fault
								bit 3	torque control	0 => automatic	1 => manual
								bit 4	laser fault	0 => running normally	1 => laser fault
								bit 5	low battery	0 => battery nominal	1 => battery low
								bit 6	flat battery	0 => battery nominal	1 => battery flat
								bit 7	system restarting	0 => system running	1 => system
								bit 8	results available	0 => result available	1 => no results available
								bit 9	power saving	0 => full power	1 => power saving active
								bit 10	user flag 1		
								bit 11	user flag 2		
								bit 12			
								bit 13			
								bit 14	spare input	0 => not active	1 => active low
		bit 15	major system flags	0 => normal	1 => abnormal						

Top level	Top symbol	Second level	Second symbol	Third level	Third symbol	Command structure	Returns	Values	Range	Units	Meaning
Inputs	I	Digital	D			?I<CR><LF>	<space>0xhhhh<CR><LF>	0xhhhh	0x0000 ... 0xffff		Returns the system status register.
						?ID<CR><LF>	<space>n<CR><LF>	n	0 ... 1	OFF/ON	Reads the status of the spare input. This is active low.

Top level	Top symbol	Second level	Second symbol	Third level	Third symbol	Command structure	Returns	Values	Range	Units	Meaning
Lasers	L					?L<CR><LF>	<space>0xhhh<CR><LF>	0xhhh	0x0000 ... 0xffff		Returns the system status register.
		Hit rate	H			?LH<CR><LF>	<space>ddd.d<CR><LF>	ddd.d	0.0 ... 100.0	%	Returns the laser hit rate.
		Distance	D			?LD<CR><LF>	<space>dd.dd<CR><LF>	aaa.a	-180.0 ... 360.0	degrees	Reads the distance of the laser range finder in the forward direction.
						?LD,aaa.a<CR><LF>	<space>dd.dd<CR><LF>	dd.dd	0.00 ... 100.00	meters	Reads the distance of the laser range finder in the direction specified.
		Firing	F			#LF,n<CR><LF>	<CR><LF>	n	0 ... 1	OFF/ON	Turns the laser firing on and off.
Bias voltage adjustment	B			#LB,nn.n<CR><LF>	<CR><LF>	nn.n	-15000 ... 15000	mV	Adjusts APD bias by the entered number of millivolts.		

Top level	Top symbol	Second level	Second symbol	Third level	Third symbol	Command structure	Returns	Values	Range	Units	Meaning
Movements	M					?M<CR><LF>	<space>0xhhh<CR><LF>	0xhhh	0x0000 ... 0xffff		Returns the system status register.
						?MB<CR><LF>	<space>0xhhh<CR><LF>	0xhhh	0x0000 ... 0xffff		Returns the system status register.
		Brushless DC motor controls	B	Trim front direction	F	?MBF,nnn.n<CR><LF>	<CR><LF>	nnn.n	-180.0 ... 360.0	degrees	Trims the rotation of the SF40 to establish the front direction. The default front position is marked on the SF40 but any direction can be chosen to suit the mounting arrangement.
					S	#MBS,n<CR><LF>	<CR><LF>				sets the speed of the BLDC motor according to the list.
				Speed	n	?MBS<CR><LF>	<space>n<CR><LF>	n	0 ... 3	identifier	Motor stopped
					1			0	0.00	rps	1654 readings per second, 1654 readings per revolution with 0.03 meters resolution.
		2				1	1.00		4578 readings per second, 2022 readings per revolution with 0.06 meters resolution.		
		3			2	2.25		9158 readings per second, 2022 readings per revolution with 0.12 meters resolution.			
		Torque	T	?MBT<CR><LF>	<space>nnn<CR><LF>	nnn	10 ... 300	units	Reads back the current value of the torque.		
		Automatic torque	A	#MBA,n<CR><LF>	<CR><LF>				Enables or disables the automatic torque control feature that compensates for motor speed and battery voltage.		
				?MBA<CR><LF>	<space>n<CR><LF>	n	0 ... 1	OFF/ON			
		Manual torque	M	#MBM,nnn<CR><LF>	<CR><LF>				Sets the torque value when operating with the automatic torque control switched off.		
				?MBM<CR><LF>	<space>nnn<CR><LF>	nnn	10 ... 300	units			
		Direction of rotation	D	#MBD,n<CR><LF>	<CR><LF>				Sets the direction of rotation of the motor to be clockwise or counter-clockwise. This allows for inverted operation whilst maintaining the same mapping orientation.		
				?MBD<CR><LF>	<space>n<CR><LF>	n	0 ... 1	CW/CCW			
				?MS<CR><LF>	<space>0xhhh<CR><LF>	0xhhh	0x0000 ... 0xffff		Returns the system status register.		
		Servo	S	0 degree trim value	Z	#MSZ,nnn<CR><LF>	<CR><LF>		Sets the 0 degree position for the servo.		
				?MSZ<CR><LF>	<space>nnn<CR><LF>	nnn	3000 ... 10500	counts			
90 degree trim value	N			#MSN,nnn<CR><LF>	<CR><LF>		Sets the 90 degree position for the servo.				
		?MSN<CR><LF>	<space>nnn<CR><LF>	nnn	3000 ... 10500	counts					
Position	P	#MSP,nnn.n<CR><LF>	<CR><LF>		Sets the aiming direction of the servo. Note that this angle can go beyond the 0 degree and 90 degree set positions.						
		?MSP<CR><LF>	<space>nnn.n<CR><LF>	nnn.n	-30.0 ... 110.0	degrees					
DC	D	?MD<CR><LF>	<space>0xhhh<CR><LF>	0xhhh	0x0000 ... 0xffff		Returns the system status register.				

Top level	Top symbol	Second level	Second symbol	Third level	Third symbol	Command structure	Returns	Values	Range	Units	Meaning
Tools	T	Mapper	M			?TM,www,aaa<CR><LF>	<space>nnn,dd,dd,dd,dd,dd.dd<CR><LF>	www	0 ... 360	degrees	Returns all distances within the specified region as a comma delimited string.
								aaa	-180 ... 360	degrees	The angular width of the region to be mapped.
								nnn	1 ... 9158	results	The direction of the region to be mapped.
								dd.dd	0.00 ... 100.0	meters	The number of results in the mapped region.
		SearchLight	S			?TS,www,aaa<CR><LF>	<space>aaa.a,dd.dd<CR><LF>				The distances returned.
								www	1 ... 180	degrees	Creates a searchlight and checks for obstacles in the direction specified.
								aaa	-180 ... 360	degrees	The angular width of the SearchLight beam.
								aaa.a	0.0 ... 360.0	degrees	The aiming direction of the SearchLight.
		Navigator	N			?TN,sss,aaa,www<CR><LF>	<space>aaa.a,dd.dd<CR><LF>				The angle of the nearest obstacle in the SearchLight beam.
								dd.dd	0.00 ... 100.0	meters	The distance to the nearest obstacle in the SearchLight beam.
								sss	1 ... 90	degrees	Finds the direction of a clear corridor within a specified region.
								aaa	-180 ... 360	degrees	The angular width of the search region.
				www	1 ... 45	degrees	The direction of the center of the search region.				
				aaa.a	0.0 ... 360.0	degrees	The width of the clear corridor required.				
				dd.dd	0.00 ... 100.0	meters	The direction of the clear corridor.				
							The distance to the closest object within the clear corridor.				

Top level	Top symbol	Second level	Second symbol	Third level	Third symbol	Command structure	Returns	Values	Range	Units	Meaning	
Outputs	O					?O<CR><LF>	<space>0xhhh<CR><LF>	0xhhh	0x0000 ... 0xffff		Returns the system status register.	
						?OF<CR><LF>	<space>n<CR><LF>				Reads back user flag 1 from the status register.	
		User flag	F	Output number	N	#OFN,n<CR><LF>	<CR><LF>	N	1 ... 2	identifier	Sets the corresponding user flag in the status register.	
						?OFN<CR><LF>	<space>n<CR><LF>	n	0 ... 1		OFF/ON	Reads back the corresponding user flag from the status register.
						?OL<CR><LF>	<space>nn<CR><LF>					Returns the linked register bit number for hardwired output 1.
		Link hardwired output	L	Output number	N	#OLN,nn<CR><LF>	<CR><LF>	N	1 => Hardwired alarm A 2 => Hardwired alarm B	identifier		Connects the specified hardwired output to the specified register bit.
						?OLN<CR><LF>	<space>nn<CR><LF>	nn	0 ... 23	identifier		
								0	alarm zone 1	0 => no alarm	1=> alarm is on	
								1	alarm zone 2	0 => no alarm	1=> alarm is on	
								2	alarm zone 3	0 => no alarm	1=> alarm is on	
								3	alarm zone 4	0 => no alarm	1=> alarm is on	
								4	alarm zone 5	0 => no alarm	1=> alarm is on	
								5	alarm zone 6	0 => no alarm	1=> alarm is on	
								6	alarm zone 7	0 => no alarm	1=> alarm is on	
								7	all alarm zones	0 => no alarms	1=> one or more alarms are on	
								8	motor stopped	0 => motor running	1 => motor stopped	
								9	motor direction	0 => clockwise	1 => anti-clockwise	
								10	motor fault	0 => no motor fault	1 => motor fault	
								11	torque control	0 => automatic	1 => manual	
								12	laser fault	0 => running normally	1 => laser fault	
								13	low battery	0 => battery nominal	1 => battery low	
								14	flat battery	0 => battery nominal	1 => battery flat	
								15	system restarting	0 => system running	1 => system	
						16	results available	0 => result available	1 => no results available			
						17	power saving	0 => full power	1 => power saving active			
						18	user flag 1					
						19	user flag 2					
						20						
						21						
						22	spare input	0 => not active	1 => active low			
						23	system	0 => normal	1 => abnormal			

Appendix B :: Dimension drawings

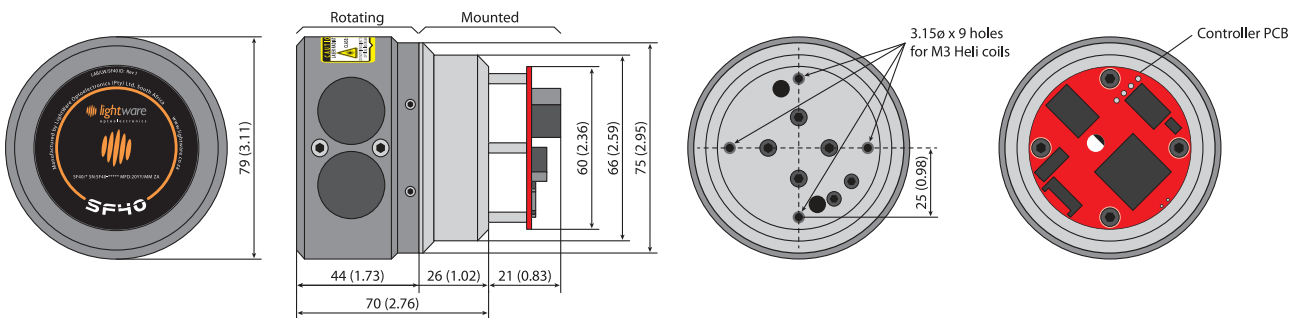
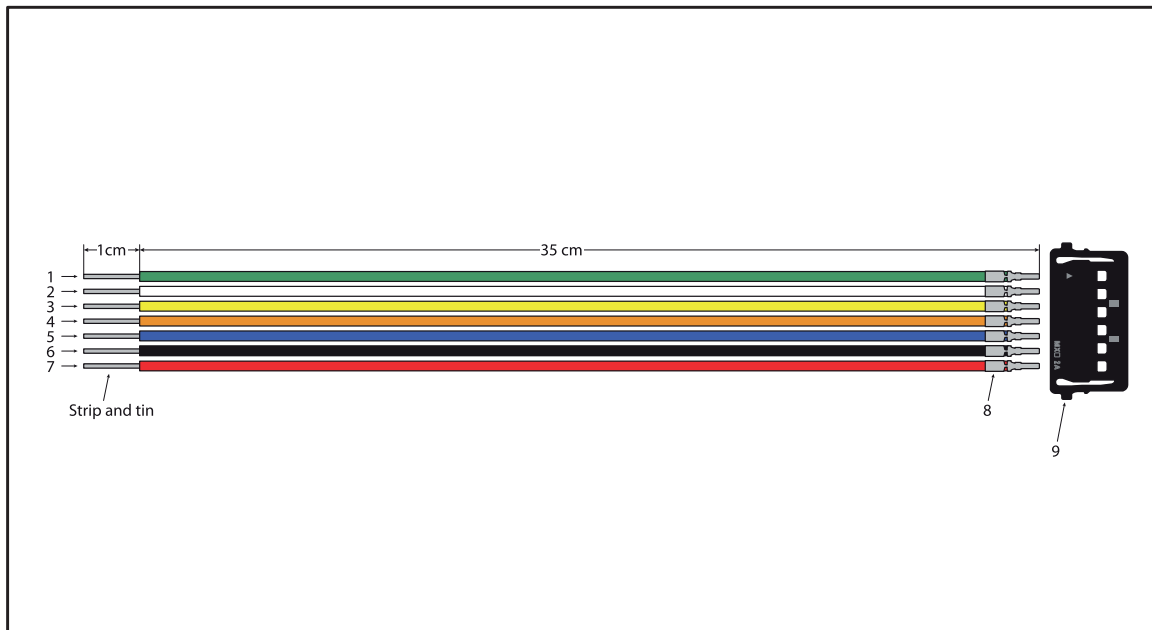

Figure 21 :: Dimension drawings of the SF40

Appendix C :: Main cable type 1, 35 cm

Note that serial user connection pin 5 is not connected and thus the blue wire “6” below is not assembled.



RS part no.	Manufacturer part no.	Description
1 RS: 177-0867	Alpha Wire: 5853 GR005	Hookup-Wire TFE Teflon Insulation, 26 AWG - Green
2 RS: 177-0839	Alpha Wire: 5853 WH005	Hookup-Wire TFE Teflon Insulation, 26 AWG - White
3 RS: 177-0889	Alpha Wire: 5853 YL005	Hookup-Wire TFE Teflon Insulation, 26 AWG - Yellow
4 RS: 177-0918	Alpha Wire: 5853 OR005	Hookup-Wire TFE Teflon Insulation, 26 AWG - Orange
5 RS: 177-0895	Alpha Wire: 5853 BL005	Hookup-Wire TFE Teflon Insulation, 26 AWG - Blue
6 RS: 177-0845	Alpha Wire: 5853 BK005	Hookup-Wire TFE Teflon Insulation, 26 AWG - Black
7 RS: 177-0851	Alpha Wire: 5853 RD005	Hookup-Wire TFE Teflon Insulation, 26 AWG - Red
8 RS: 789-8378	Molex: 504052-0098	Pico-Lock contact terminal 24-28 AWG
9 RS: 789-8371 P	Molex: 504051-0701	Pico-Lock wire to board housing 7 way

NOTE: Wire colours are critical. Do not deviate.

 LightWare Optoelectronics (Pty) Ltd	Main cable type 1 assembly	Rev: 0
---	----------------------------	--------

Appendix D :: Power cable assembly, 30 cm

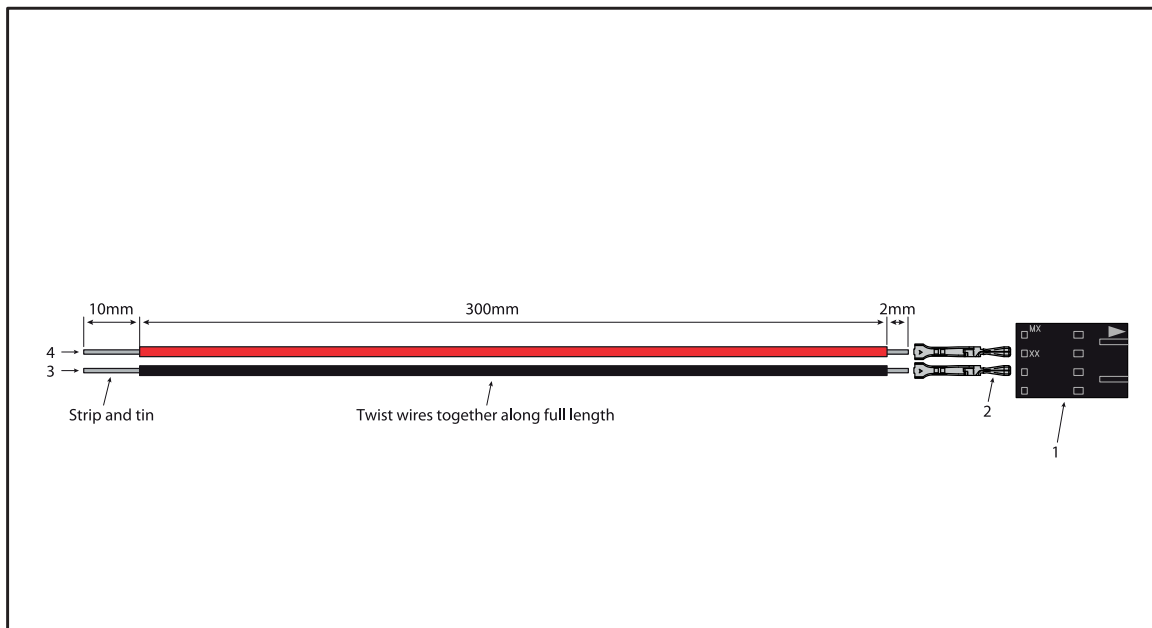

Part no.	Manufacturer part no.	Description
1 DK: WM2900-ND	Molex: 0050579402	Latch Lock Connector Housing, 2.54mm Pitch, 2 Way
2 DK: WM9138-CHD	Molex: 0016020082	Contact Terminal 24-30AWG 15GOLD
3 RS: 177-0845	Alpha Wire: 5853 BK005	Hookup-Wire TFE Teflon Insulation, 26 AWG - Black
4 RS: 177-0851	Alpha Wire: 5853 RD005	Hookup-Wire TFE Teflon Insulation, 26 AWG - Red

NOTE: Wire colours are critical. Do not deviate.

 LightWare Optoelectronics (Pty) Ltd	LW 000-165: Power cable assembly	Rev: 0
---	----------------------------------	--------

Appendix E :: USB cable assembly, 1.8 m

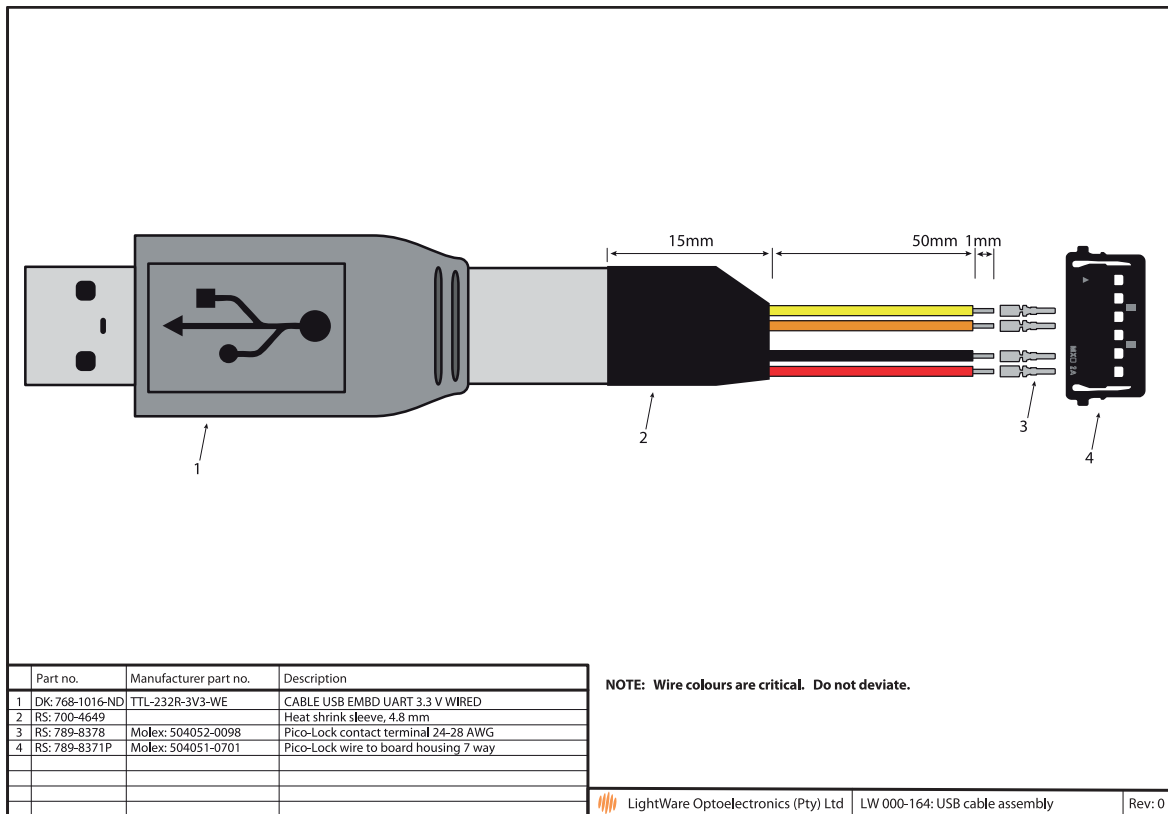

Revision history

Version	Date	Authors	Comments
Rev 6	2017/08/18	TLP	Updated branding and layout of this document has resulted in page number changes to previous revision history entries. Added "User power supply voltage" of "2.7 V ... 5.5 V DC" in "Appendix A :: Specifications" (page 4). Clarified the values for "Revolutions per second / Measuring mode", "Resolution", "Readings per revolution" and "Readings per second" (pages 4, 18).
Rev 5	2016/09/05	TLP	Corrected baud rate to "115200" (page 8). Updated FDA accession number "1630995-000 (2016/09)" in "Appendix A :: Specifications" (page 18).
Rev 4	2016/05/27	TLP	Updates to this document revision are applicable from SF40/* SN: SF40-00014, firmware revision 0.1. Include "Note - The SF40 is designed to collect and analyze data internally. Whilst this data can be downloaded to an external controller, the SF40 is not intended to provide a continuous data stream. Attempting to download data continuously will result in a significantly reduced update rate." (page 3). Include user selectable baud rate functionality (pages 8 & 9).
Rev 3	2016/03/18	TLP	Amended "Update rate" description to "1, 2.25 or 4.5 revolutions per second. 1164, 4578 or 9158 readings per second" in "Appendix A :: Specifications" (page 18).
Rev 2	2016/03/03	TLP	Included "Appendix D :: Main cable type 1, 35 cm" (page 19). Included "Appendix E :: Power cable assembly, 30 cm" (page 20). Included "Appendix F :: USB cable assembly, 180 cm" (page 20).
Rev 1	2016/01/29	TLP	Update FDA accession number "1410968-002 (2016/01)" in "Appendix A :: Specifications" (page 18).
Rev 0	2016/01/22	JEP	First edition